

RAILWAYS AND URBAN TRANSPORT

COMPANY PROFILE AND
STATEMENT OF CAPABILITIES 2024

CONTENTS

- 1 COMPANY PROFILE 2**
 - ABOUT TECHNITAL2
 - Description.....2*
 - Services.....2*
 - Organization and staffing3*
 - Quality control.....4*
 - Areas of Specialization5*
- 2 OUR EXPERIENCE..... 6**
 - EXPERIENCE IN RAILWAYS6
 - EXPERIENCE IN URBAN TRANSPORT10
- APPENDIX A – COMPANY’S EXPERIENCE.....24**
 - RAILWAYS
 - URBAN TRANSPORT

1 Company Profile

About TECHNITAL

Description

TECHNITAL is a private joint stock company established more than 50 years ago (in 1964) and is one of the oldest engineering consultancy companies in Italy. Thanks to its high level of expertise, its dynamic nature and versatility, management autonomy and efficiency and its sophisticated hardware equipment and software libraries, the Company has been awarded large scale international and national projects by major public and private entities and by international funding organizations.

TECHNITAL's headquarters are situated in Verona, Italy. The organization abroad includes 15 between branches and subsidiaries in Algeria, Armenia, Benin, Bosnia & Herzegovina, Croatia, Georgia, Iraq, Kenya, Kosovo, Qatar, Tanzania, Trinidad & Tobago, Tunisia, Uruguay and Zambia and a number of local offices which is continuously changing according to the on-going international projects (at the moment there are 4 local site offices).

Services

TECHNITAL is a dynamic company working in the fields of transport infrastructure (roads and motorways, railways, inland waterways, urban transport, ports and airports), hydraulics (water treatment and desalination plants, dams, aqueducts, sewerage systems, waste water treatment), marine and coastal engineering, environment, energy (incineration and waste-to-energy plants, hydroelectric plants, solar plants, biogas plants), waste treatment (recycling plants, dump sites), buildings, architecture and urban planning.

The company covers the full range of services, from planning and feasibility studies through to detailed design, works supervision and technical assistance:

- } project management
- } planning and economic-financial evaluation of investments
- } feasibility studies and technical-economic evaluations
- } all levels of design
- } environmental impact assessment and studies
- } traffic studies
- } procurement and assistance with tenders
- } construction supervision, quality assurance, testing and commissioning
- } co-ordination and supervision of research and laboratory tests
- } development of hydrodynamic and hydrogeological analysis and simulations
- } development and application of analysis methods and computer modelling.

TECHNITAL has worked in several countries world-wide: Afghanistan, Albania, Algeria, Angola, Argentina, Armenia, Australia, Austria, Bahamas, Benin, Bolivia, Bosnia & Herzegovina, Brazil, Bulgaria, Burkina Faso, Burundi, Cayman Islands, Colombia, Croatia, Cuba, Cyprus, Czech Republic, Democratic Republic of the Congo, Denmark, Djibouti, Dominican Republic, Egypt, Ethiopia, Georgia, Germany, Ghana, Greece, Guatemala, Hungary, India, Iraq, Italy, Jordan, Kenya, Kosovo, Libya, Madagascar, Malawi, Malaysia, Mali, Mauritania, Monaco, Montenegro, Mozambique, Nicaragua, Niger, Norway, Panama, Peru, Poland, Qatar, Republic of Haiti, Romania, Russia, Rwanda, Saudi Arabia, Senegal, Slovenia, Somalia, Spain, Sudan, Syria, Tanzania, Togo, Trinidad & Tobago, Turkey, Uganda, Ukraine, U.A.E., United Kingdom, U.S.A., Uruguay, Venezuela, Yemen, Zambia.

Organization and staffing

TECHNITAL's multidisciplinary staff is organized according to the following chart:

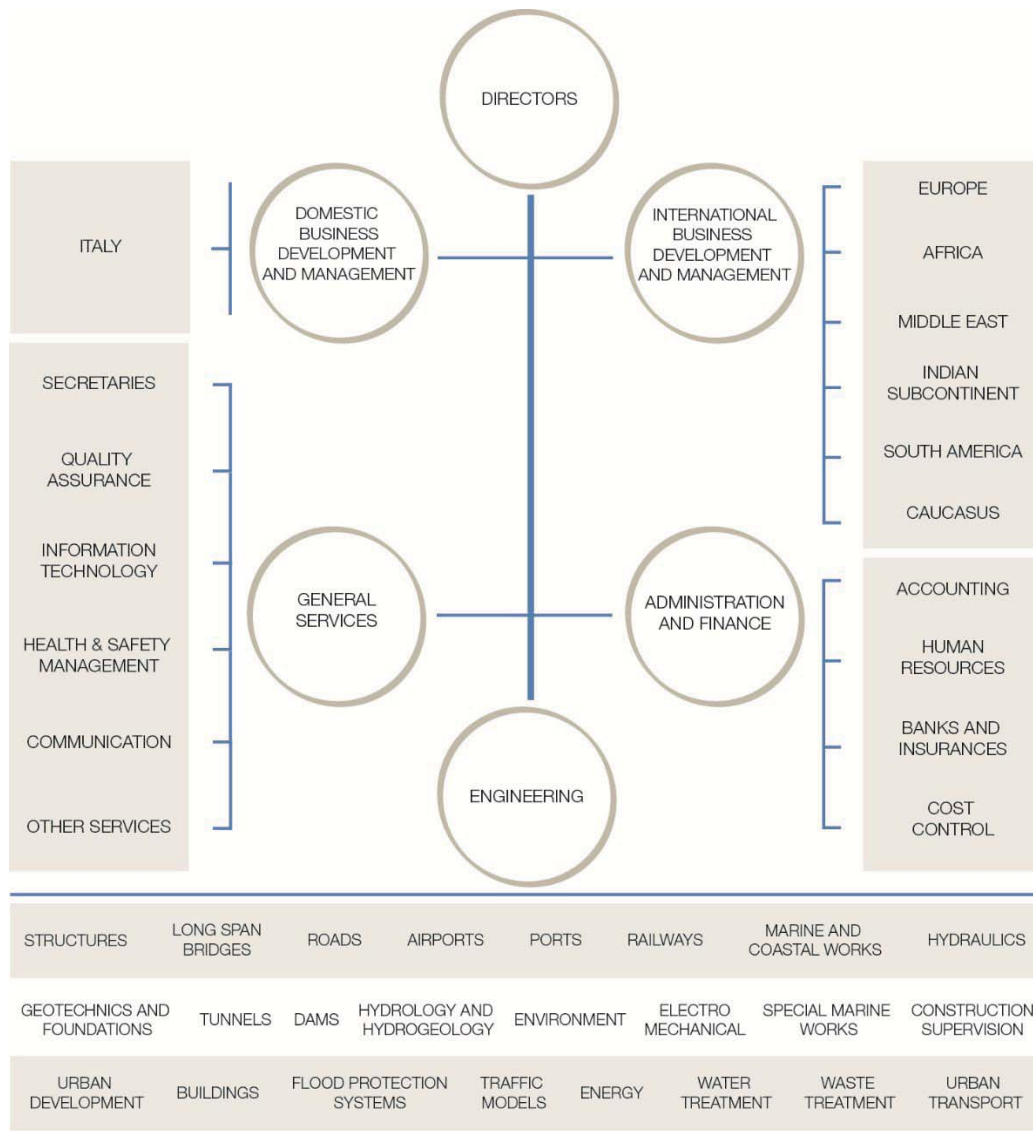

TECHNITAL's multidisciplinary staff includes about 250 professional employees covering the various aspects of the engineering services: Transport, Hydraulics, Geotechnical, Marine & Coastal, Environmental Studies & Territorial Analysis, Structures, Electronic Data Processing & Systems Analysis, Quantity Surveying & Cost Estimation, Electromechanics, BIM/CAD/CAE, Works Supervision, etc.

The above staff is integrated by consultants and specialists, both Italian and foreign. Seeking support and advice from colleagues, scientists, and academics all over the world is part of TECHNITAL's policy of excellence.

Given the firm's considerable international experience, TECHNITAL's staff is proficient in the use of international engineering standards (BS, ASTM, AASHTO, ASME, API and the like) and contract conditions (FIDIC and others).

Quality control

TECHNITAL's activity is ISO 9001:2015 Quality System Management certified. The company is also certified ISO 14001: 2015 Environmental Quality Management, ISO 45001:2018 Occupational Health and Safety Management System and SA 8000:2014 Social Accountability Management System.

TECHNITAL has developed a company policy regarding quality control which is constantly being updated and applied, taking into account the costs to be sustained to achieve the objectives of quality and maximum benefit for both the Company and the Client. Thanks to its Quality Control System, TECHNITAL is capable of guaranteeing the quality of its services and of ensuring the Client that these services satisfy the required quality standards.

Code of Ethics

Ethical and responsible decision making is very important for the company in terms of risk management and in order to keep actions within the ethical and legal boundaries.

For that reason, the company is adopting a Code of Ethics (available from the web site of the company) and conduct for its Executives and Directors and for all the Employees able to fulfil requirements for responsible decision taking. Such code aims at reducing the possibility of stepping outside behavioral limits set by the company.

The Code of Ethics the company is adopting also meets the Organization, Management and Control Model pursuant to Italian Legislative Decree n. 231/2001.

Sectors of Specialization

TECHNITAL provides high-quality consultancy services in different areas of specialization: Roads and Motorways, Railways and Urban Transport, Airports, Ports and Waterways, Marine and Coastal Engineering, Environmental Engineering, Urban Planning, Buildings and Architecture, Hydraulic Engineering, Water Treatment, Waste Treatment, Energy.

In each of these sectors TECHNITAL provides innovative project solutions to Government Agencies, International Financial Institutions and Private Sector Organizations.

Services provided by TECHNITAL include master plans, feasibility studies, techno-economical evaluations, traffic studies, mathematical and physical modeling, all phases of design from concept to detailed design, environmental impact studies and monitoring plans, tender document preparation and assistance in the procurement of works, construction supervision.

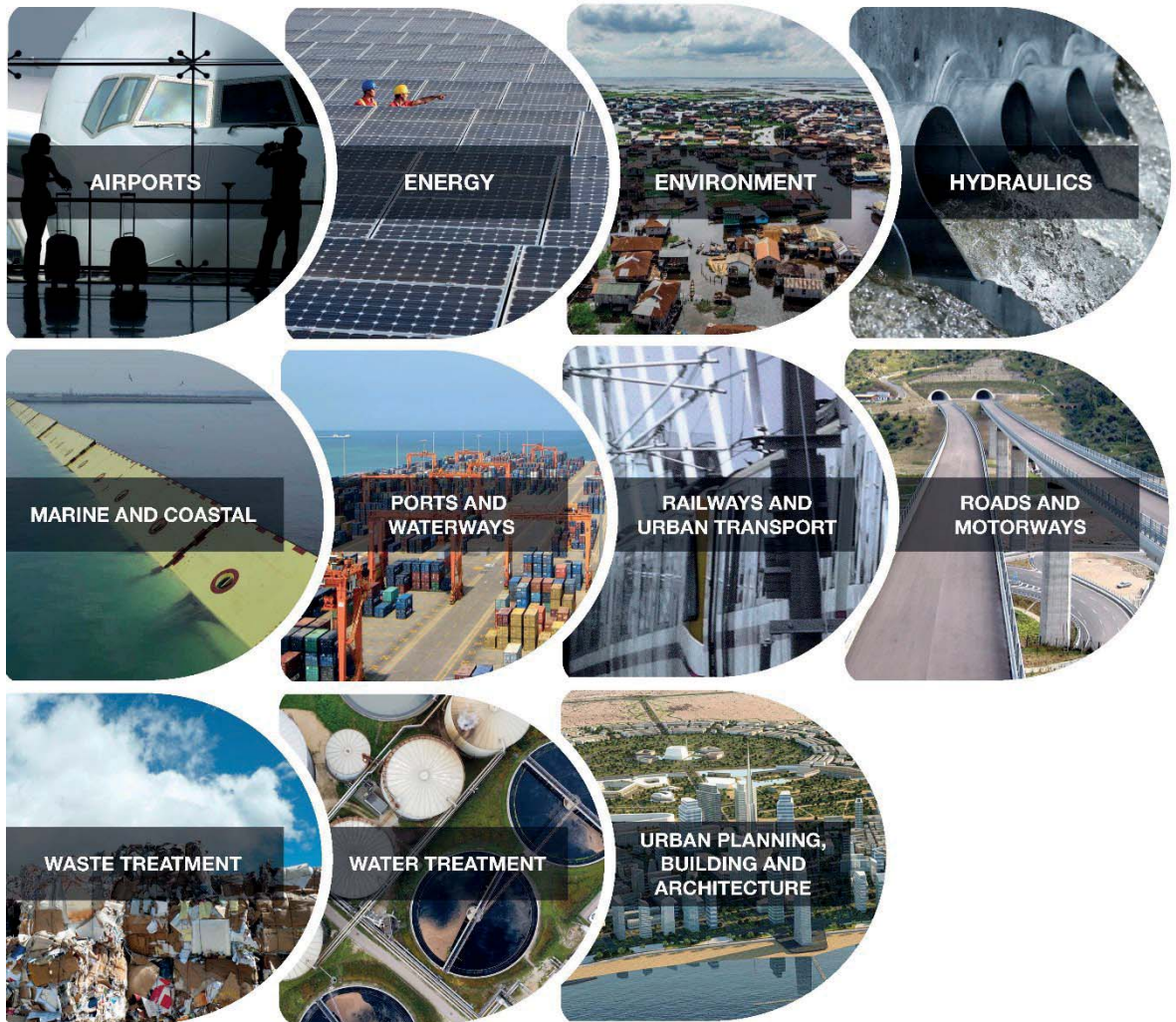

[

2 Our Experience

Experience in Railways

The experience of TECHNITAL in the field of railways dates back from the 1980s. It includes planning, design and work supervision of various international and Italian infrastructures.

Railway engineering is multi-disciplinary expertise which incorporates logistical operation, structural, infrastructural, installation aspects. TECHNITAL provides integrated general engineering services from planning, master plans, feasibility studies, technical-economic evaluations, traffic studies, modeling, all phases of design from concept to detailed design, environmental impact studies and monitoring plans, tender document preparation and assistance in the procurement of works, construction supervision. Services covers civil works and alignment, stations, technological systems, yards and workshops, rolling stock and operation.

Among the most recent assignments the Company has recently undertaken the **“PMC for the implementation of the railway link between the Airport of N’Djili and Kinshasa Central Station”** in the Democratic Republic of the Congo and the **“Detailed Design of the alignment and permanent way of the High Speed Railway from El Ain Sokhna on the Red Sea to Marsa Matrouh on the Mediterranean Coast”**. The line, also called **“High Speed Green Line”**, is the Egypt’s first-ever high-speed rail line and it is part of larger railway high speed development project recently undertaken by the Egyptian Government. It will connect the port cities of Ain Sokhna on the Red Sea and Marsa Matrouh on the Mediterranean Sea, passing near Cairo and the New Administrative Capital located 30 miles east of Cairo, for an overall length of 660 km.



Moreover, the Company has recently completed the **Construction of Second Track and Construction of New Double Track Line on railway section Hrvatski Leskovac – Karlovac** in Croatia and the **Development of the national Master Plan for railway operations and maintenance (O&M), legal framework, management system** in Ethiopia.

TECHNITAL has played a vital role in the domestic market of railway design having developed important assignments such as the Detailed and Construction design of two sections of **Milan-Bologna link of the Milan-Naples High Speed Line** in Italy (300 kph design speed), near the cities of Piacenza and Modena (total length of designed line approx. 40 km) and the interconnection with the existing line in Modena.



The main Line project includes viaducts, cut and cover tunnels, underpasses and flyovers, hydraulic works and auxiliary roads and buildings, as well as landscaping works.



Bridge under construction on the high-speed railway, Piacenza – Italy

The project includes 7 railway viaducts with prestressed deck, one of which over 5 Km long. The interconnection with the existing line in Modena regards the shifting of the existing-Milan-Bologna line outside the Modena city limits, the doubling of the existing Modena-Mantua line for the connection to the high-speed line, and the branch line for freight trains to these lines, for a total line length of approximately 13 km. It includes a cut and cover tunnel 2 km long.



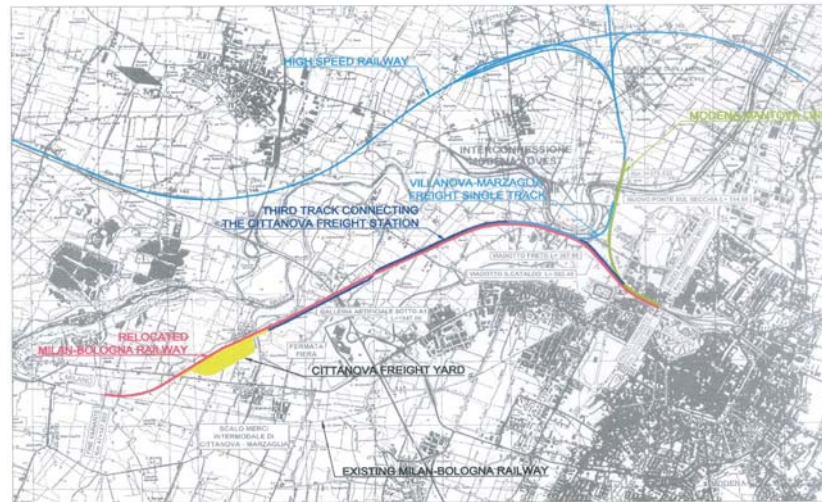

Relocation of the existing railway line, Modena - Italy

A very important project in the history of the company is the **Renewal of the existing line Dammam – Hofuf-Harad - Al Kharj - Riyadh (560Km) and New Direct line Dammam – Hofuf – Riyadh (449 Km)** in Saudi Arabia. The project was covering the development of what at that time was the overall Saudi Railway Network and it included services from Feasibility Study, Concept, Preliminary and Detailed Designs, Tender Documents, Construction Supervision, up to the Technical Assistance.

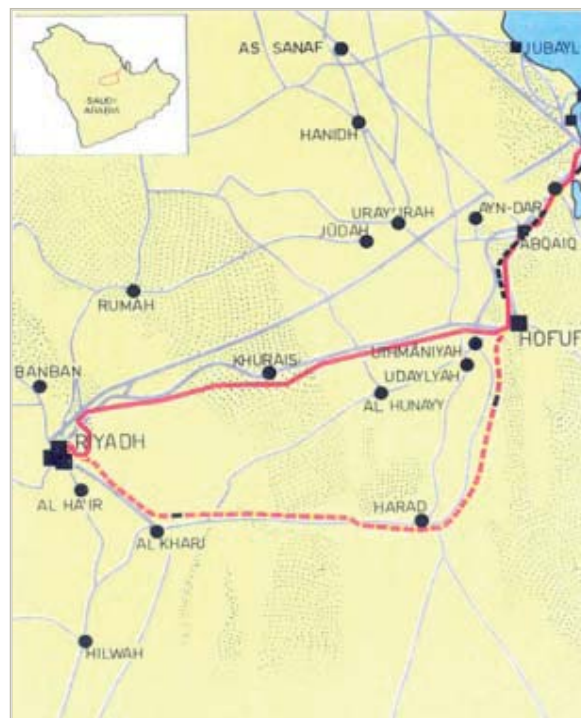

Development of the Saudi Arabia railway network Project

Another milestone in the history of TECHNITAL is the **Integrated Transportation System for the development of the Kagera River Basin** covering Burundi – Rwanda – Tanzania – Uganda. The Kagera River Basin region lies 1,000 km from the Indian Ocean and 1,900 km from the Atlantic Ocean. The idea was to study the possibility to establish railways corridors as follows:

- ↳ North Corridor which connects through to the port of Mombasa in Kenya across Lake Victoria, using the existing line Kasese (Uganda)-Nairobi-Mombasa;
- ↳ Central Corridor which connects through to the port of Tanga in Tanzania across Lake Victoria, using the existing line Arusha (Tanzania)-Tanga;
- ↳ South Corridor which connects through to the port of Dar Es Salaam in Tanzania, using the existing line Kigoma (Tanzania)-Dar Es Salaam.



Kagera River Basin Project (Burundi, Rwanda, Tanzania, Uganda)

A project recently completed has been the design for **Malpensa Airport T2 link up to the New Railway Station at Terminal 2 and Railway Link T1-T2**. Lot 1 regards the new underground railway station at Terminal 2 of Milan Malpensa Airport, with a 2-level car park located above the station, connected by a pedestrian link to the passenger Terminal 2. Lot 2 regards the double-track railway link T1-T2 of a total length of 3.15 km which develops entirely below the ground level. It includes No. 5 cut-and-cover tunnels for a total covered length of 1 Km. The tunnel construction method is different based on the surface constraints: either top-down method with r.c. pile walls or prefabricated or cast in place structures within open excavation.



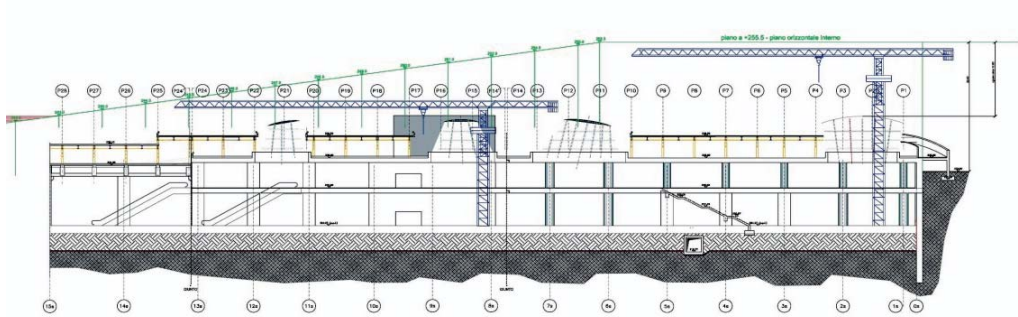

Malpensa Airport T2 link up Project, Italy

Experience in Urban Transport

In the field of Metro lines, TECHNITAL has developed the design for the **Automatic Metropolitan Light Railway for the city of Palermo – First Line: Oreto – Notarbartolo**. The project concerned a first functional section of the metropolitan light railway of Palermo, running in a north-south direction across the central city area, from the intersection of Oreto and the ring road (Viale della Regione Siciliana) to the Notarbartolo railway station, for a total length of 6.5 km, plus a 0.5 km link to the depot. The line section includes 9 stations.

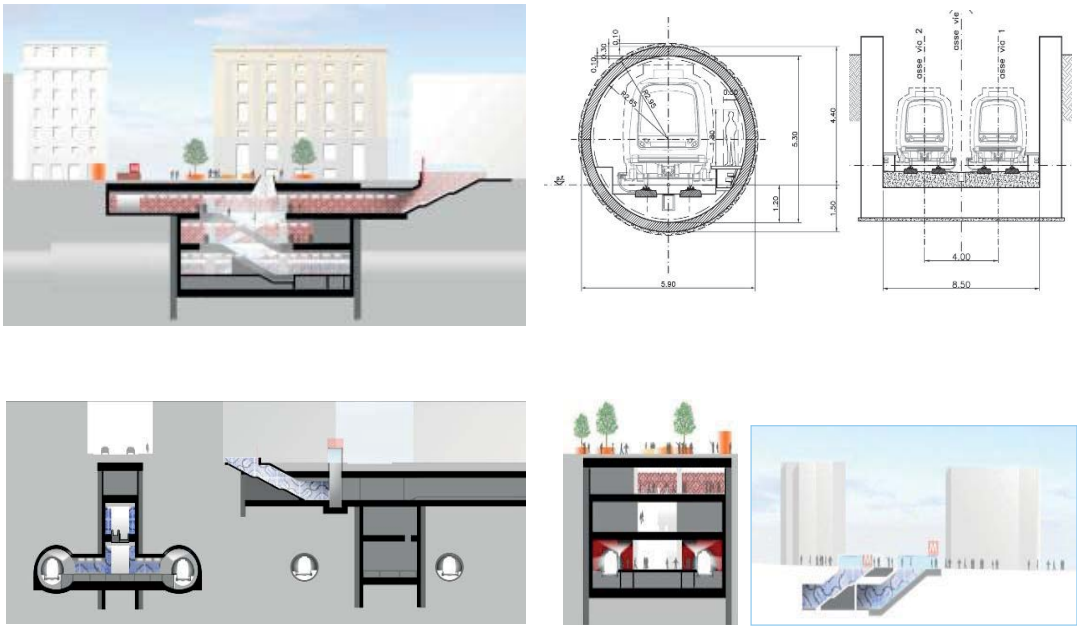

Automatic Metropolitan Light Railway in Palermo, Italy

As part of Metro lines' projects, it is worth mentioning the **Light Rail Line 2B of Santo Domingo – Cable Stayed Bridge over Rio Ozama**. The bridge has a deck about 520 m long, subdivided in 5 spans: the central one (between the pylons) is 270 m long, while the 2 adjacent ones on each side are 65 m and 60 m respectively.



Cable Stayed Bridge on the Light Rail Line, Santo Domingo

Among other activities, TECHNITAL has been in charge of the aerodynamic analysis by wind tunnel tests.

In the field of trolley bus system, TECHNITAL has acquired a valuable experience. In this regard it is of utmost importance to mention the detailed design of the **Trolleybus of Genoa City** which refers to the new implementation and upgrading of about 50 km of trolleybus system. The goal is to equip the city with a widespread system on major city routes that is quick to implement, flexible in operation, and with zero pollutant emissions. It includes depot and workshops as well as the construction of 2 new parking facilities at the Campanule and Staglieno sites.



Rendering of the upgraded trolley-bus depot Genova, Italy



Rendering of the new Staglieno multi-storey parking lot and workshop building, Genova, Italy

Moreover, the company has undertaken the design of the **Trolley Bus Transport System in Verona** which is very delicate due to the historical environment of the town. It includes the design of 4 lines and of the related depot and workshops.



Rendering of the Stop in front of the castle of Castelvecchio in Verona, Italy

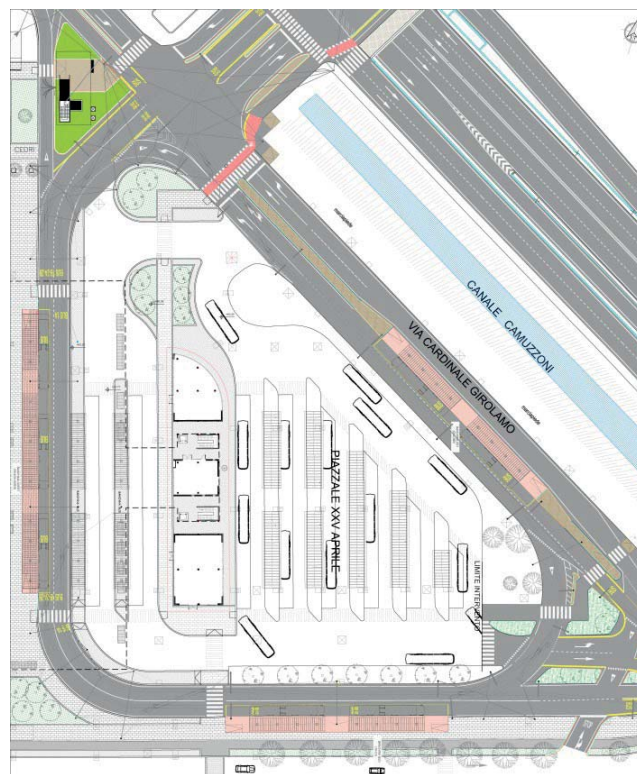

Layout of the terminal at the Main Station of Verona, Italy

Furthermore, TECHNITAL has also active in the field of tramway system. It has recently undertaken the design of the **line 4 (section Campi Bisenzio – Sesto Fiorentino) of the tramway in Florence**. The line includes 11 stops, 4 park-and-ride parking lots, an area for streetcar storage and maintenance, and 4 main works of art to cross the hydrographic network, the largest of which has a length of almost 140 m. The project envisages the construction of several buildings within the "Depot Area (approx. 32,900 sqm), which are mainly required for office accommodation, material storage and vehicle maintenance.



Rendering of a typical stop of the tramway in Florence, Italy



Layout of the buildings within the new "Depot Area" in Florence, Italy

The company has undertaken the design of **Fast Tram Parco Nord Seregno** in Milan. The infrastructure is a double track line length of the is about 14.3 km and includes the related depot/workshop.



View of the line in a specific intersection, Milan, Italy

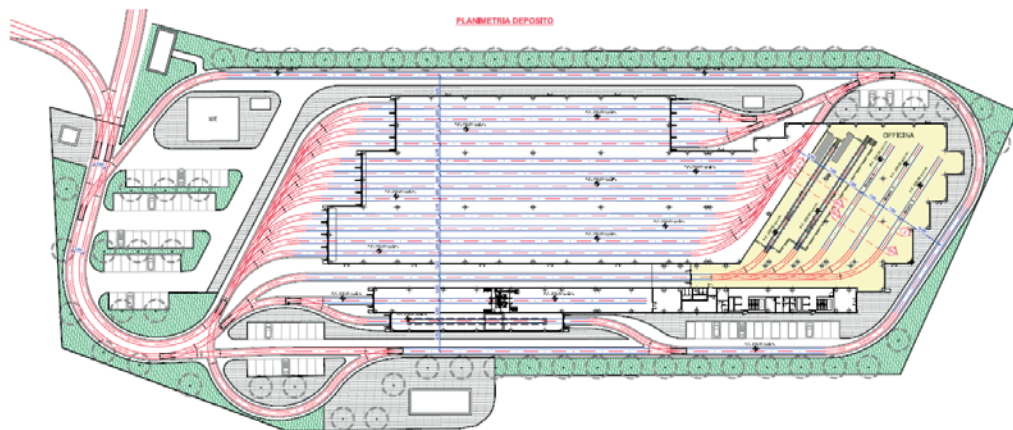

Layout of the depot/workshop, Milan, Italy



Rendering of the depot/workshop, Milan, Italy

Other relevant projects are the following:

- ⌋ Technical and economic feasibility study of Al Zarqa – Traibil Railways Line (300 km) - Jordan;
- ⌋ Antsirabe - Fianarantsoa Railway Line (242 km) -Madagascar;
- ⌋ Works for the Upgrading of the Adria-Mestre Railway Line – Italy;
- ⌋ Preliminary Design of Interventions for the Completion of Modernisation Program of the Circumetnea Railway Line, Italy
- ⌋ Messina - Palermo railway line: Rometta – Pace del Mela Section – Italy
- ⌋ Railway link from Bari town centre to Bari-Palese Airport - Italy
- ⌋ Palermo – Agrigento Railway Line – Italy
- ⌋ Upgrading and doubling of the Udine-Pontebba railway line (65 km) - Italy
- ⌋ Modernisation of the Adria-Mestre Railway Line – Italy
- ⌋ Upgrading and doubling of the Orte-Falconara Railway and branch line to the Adriatic line – Italy
- ⌋ Detailed Design of the of the First Tramway Line (Red Line) in Bologna - Italy
- ⌋ Detailed Design of the Tramway between Rende and the University of Calabria in Cosenza – Italy

- } Detailed Design of the doubling of the Roma – Viterbo Railway – Section Riano – Castelnuovo di Porto – Italy
- } Detailed Design of the Line 3 (section Libertà – Bagno a Ripoli) of the Tramway in Florence – Italy

The long experience acquired in this field has allowed the progressive development of planning, research and study methods which have led to the steady improvement in the quality of the product with considerable benefits to costs and performance times.

For the execution of the different activities within the railways field, characterized by a high degree of interdisciplinary and specialization, TECHNITAL has at its disposal a multidisciplinary team, and innovative and avant-garde computer software.

Environment is certainly an issue while dealing with railway projects and a special attention is paid in this respect to the qualification and quantifications of such aspects even by measuring them seeking to mitigate effects in accordance with a philosophy of "integrated design", typical of environmental impact studies, where environmental considerations are fundamental for determining the ideal design options.

Services provided by TECHNITAL include:

1. Consulting
 - } Master-plan
 - } Traffic studies
 - } Operation, rolling stock and maintenance studies
 - } Technical-economic feasibility studies,
 - } Financial analyses,
 - } Socio-economic analyses
 - } Transport system planning
2. Design
 - } All phases of design from preliminary up to construction design for line, station, yards, depot, technologies, workshop and other maintenance facilities
 - } Technical specifications, contracts, construction planning, cost estimates
 - } Environmental impact studies
 - } Tender documents preparation and procurement
3. Supervision
 - } Construction management and supervision
 - } Technical assistance during tender phase
 - } Works supervision
 - } Coordination and supervision of research and laboratory tests
 - } Environmental monitoring

Full details of the main projects executed are given in the following tables and related project sheets.

TABLE A – COMPANY’S EXPERIENCE (For titles in **bold** type see project sheets in Appendix A)

PROJECT	CLIENT	PERIOD		ACTIVITIES	COST OF SERVICES €	COST OF WORKS €
		FROM	TO			
RAILWAYS						
Investigation and detailed design of upgrading of various bridges on railways touristic lines in Sardinia region - Italy	RFI – Rete Ferroviaria Italiana	02/2024	Ongoing	Detailed design and investigations	4,166,600	49,000,000
Detailed design of intermodal (maritime/rail/road) platform of Molfetta - Italy	ISTOP SPAMAT S.r.l.	05/2023	Ongoing	Detailed Design	1,049,740	70,000,000
PMC for the implementation of the railway link between the Airport of N’Djili and Kinshasa Central Station - Democratic Republic of the Congo	TCC – Metrokin	10/2022	Ongoing	Feasibility Study, Preliminary Design, Detailed Design and Works Supervision	13,400,000	Confidential to be tendered
Detailed Design of Alignment and Permanent Way of the High-Speed Railway Line from Ain El Sokhna City on the Red Sea Coast to Marsa Matrouh on the Mediterranean Coast – Egypt	Orascom Construction S.A.E. and Arab Contractors (Osman Ahmed Osman & Co.)	03/2022	Ongoing	Detailed Design	1,866,250	600,000,000
Detailed Design of the doubling of the Roma – Viterbo Railway – Section Riano – Castelnuovo di Porto – Italy	ASTRAL S.p.A.	09/2020	Ongoing	Detailed Design	982,536	48,920,325
Brcko Port - Procurement and Contract Implementation Support – Bosnia and Herzegovina	Public Company Port of Brcko Ltd	06/2020	Ongoing	Tender Documents, Work Supervision	949,134	9,300,000

PROJECT	CLIENT	PERIOD		ACTIVITIES	COST OF SERVICES €	COST OF WORKS €
		FROM	TO			
Construction of Second Track and Construction of New Double Track Line on railway section Hrvatski Leskovac – Karlovac, Croatia	Croatian Railways Infrastructure Ltd.	11/2012	01/2021	Feasibility Study, Preliminary and Detailed Design,	7,100,000	315,000,000
Detailed Design of the New Trenitalia Current Maintenance Centre “Torino Smistamento” in the city of Turin – Italy	Vianini Lavori S.p.A. (Contractor) Italferr S.p.A. in name of Trenitalia S.p.A. (Contracting Authority)	09/2014	04/2017	Detailed Design	1,170,000	124,895,000
Development of The National Master Plan for Railway Operations and Maintenance (O&M), Legal Framework, Management System – Ethiopia	Ethiopian Railways Corporation	01/2014	07/2017	Master plan, railway operation and maintenance guidelines, specifications, Capacity Building	1,233,000	12,500,000,000
Hydrological and hydraulic studies for the design of the Railway North Nseluka-Mpulungu and Railway South Livingston-Sesheke - Zambia	MTWCS - Ministry of Transport, Works, Supply and Communications	01/2016	12/2016	Hydrological and hydraulic analysis and reports	58,770	n.a.
High speed railway line Milan-Bologna: Relocation of the Existing line in the Province of Modena (Lot 4.A) – Italy	Grandi Lavori Fincosit - Roma for Cepav Uno Consortium	06/2004	12/2016	Final and Detailed Design, Technical Assistance	3,362,000	90,210,070
Preliminary Design of Interventions for the Completion of Modernisation Programme of the Circumetnea Railway Line, Italy	Ministry Of Infrastructures and Transport General Department of Local Public Transport Circumetnea Railway	10/2009	07/2016	Preliminary Design EIA	3,031,000	1,325,693,754

PROJECT	CLIENT	PERIOD		ACTIVITIES	COST OF SERVICES €	COST OF WORKS €
		FROM	TO			
Tender Design Services for Detailed Design of Production facilities and logistics of Fehmarnbelt Fixed Link (road and railways) in Lolland - Contracts for Tunnel North (TUN) & Tunnel South (TUS) – Denmark - Germany	JV Salini Impregilo – Samsung C&T Corporation – Bunte	02/2014	06/2016	Tender Design	292,000	150,000,000
Consultancy engineering service elaboration of the concept design (deck only) for the bridges of the north west rail link - Australia	Salini Impregilo	04/2014	12/2015	Design Assessment	130,000	n.a.
Malpensa T2 Link-Up - New Railway Station at Terminal 2 (Lot 1) and Railway Link T1-T2 (Lot 2) - Malpensa Airport – Italy	S.E.A. S.p.A. / Nord Ing S.r.l.	04/2012	07/2015	Final Design	354,364	92,442,700
Doubling of the main line between Hofuf and Riyadh. Design for the doubling of the existing bridge at km 426 of the Dammam–Riyadh railway line- Saudi Arabia	Saudi Archirodon Ltd.	03/2012	12/2014	Preliminary, Final and Detailed Design	200,000	n.a.
High speed railway line Milan-Bologna: Design and construction of a section in the Province of Piacenza (Lot 1.4, total length of approx. 28 km) – Italy	Grandi Lavori Fincosit - Roma for Cepav Uno Consortium	08/2001	12/2010	Final and Detailed design, Ttechnical Assistance	7,334,000	242,431,000
Messina - Palermo railway line: Rometta – Pace del Mela Section – Italy	Italferr	07/2002	09/2009	Preliminary, Final and Detailed Design; Works Supervision.	1,292,600	41,882,800

PROJECT	CLIENT	PERIOD		ACTIVITIES	COST OF SERVICES €	COST OF WORKS €
		FROM	TO			
Milan Malpensa Airport: new underground railway tunnel of the New Cargo City, Italy	S.E.A. S.p.A.	06/2006	01/2008	Detailed Design	145,380	12,900,000
Palermo – Agrigento railway line - Sicily, Italy	RFI Palermo	08/2003	12/2007	Preliminary and Final Design, Tender Documents	5,039,700	166,472,000
Modernization of the Adria-Mestre railway line - Veneto, Italy	Sistemi Territoriali	03/2003	11/2003	Preliminary and Final Design	2,003,900	56,000,000
Milan-Naples high-speed railway line: Milan-Bologna section - Italy. Civil works for 18 km section (KP 45-63), Italy	Grandi Lavori Fincosit - Roma for Cepav Uno consortium	01/1997	12/1999	Detailed Design	774,700	108,000,000
Al Zarqa-Traibil railway line (300 km), Jordan	Jordanian Ministry of Transport	07/1995	05/1996	Technical - Economical Feasibility Study	247,900	371,849,000
Development of the Saudi railway network: Renewal of the existing line Dammam-Hofuf-Harad-Al Kharj-Riyadh (560 km), and new direct line Dammam-Hofuf-Riyadh (449 km), Saudi Arabia	S.R.O. - Saudi Railway Organization - Dammam	01/1978	12/1992	Feasibility Study, Preliminary and Detailed Design, EIA, Tender Documents, Works Supervision, Technical Assistance	17,766,100	516,500,000
Upgrading and doubling of the Orte-Falconara Railway and branch line to the Adriatic line, Italy	Consortium Co.Ma.Vi. on behalf of the EnteFerroviedello Stato (Italian State Railways)	03/1984	02/1989	Preliminary and Detailed Design, EIA	1,058,700	77,985,000

PROJECT	CLIENT	PERIOD		ACTIVITIES	COST OF SERVICES €	COST OF WORKS €
		FROM	TO			
New railway marshalling yard of Roja at Ventimiglia, – Italy	Consortium IBIS-Bertolo-Lombardini- CIR-Cavestrade on behalf of the Italian State Railways	01/1983	12/1988	Concept, Preliminary and Detailed Design, EIA	521,600	20,865,000
Integrated Transportation System for the development of the Kagera River Basin, Burundi, Rwanda, Tanzania, Uganda	Kagera Basin Organization - U.N.D.P. – (fin. Italian & Austrian Governments)	05/1982	12/1984	Feasibility Study; Preliminary Design	1,817,900	n.a.
Upgrading and doubling of the Udine-Ponterebba railway line (65 km), Italy	Icomec S.p.A.	01/1975	12/1978	Feasibility Study, Preliminary Design, Detailed Design	1,239,500	154,937,000
Antsirabe - Fianarantsoa Railway Line, Madagascar	Malagasy National Railways - Tananarive	01/1971	12/1977	Detailed Design	826,300	77,468,500
URBAN TRANSPORT						
Detailed Design of the Line 4 (section Campi Bisenzio – Sesto Fiorentino) of the Tramway in Florence – Italy	Municipality of Florence	11/2023	Ongoing	Detailed Design	5,408,334	178,069,427
Detailed Design of the Line 3 (section Libertà – Bagno a Ripoli) of the Tramway in Florence – Italy	Municipality of Florence	11/2023	Ongoing	Detailed Design	1,800,000	201,724,000

PROJECT	CLIENT	PERIOD		ACTIVITIES	COST OF SERVICES €	COST OF WORKS €
		FROM	TO			
Bari – Lecce Railway Line: re-alignment of the section between Bari Central and Bari – Torre a Mare – Italy	Impresa D'Agostino Angelo Antonio Costruzioni Generali	07/2020	Ongoing	Detailed Design	1,000,000	81,906,924
Palermo Tramway System – Italy	Municipality of Palermo	07/2018	Ongoing	Feasibility Study, Detailed Design, Works Supervision	16,412,620	516,507,300
Detailed design of the new urban rail section Germaneto - Sala and upgrading of the existing section Sala – Lido in Catanzaro – Italy	Regione Calabria	10/2015	Ongoing	Detailed Design Contractor Assistance	1,014,000	88,038,312
Detailed Design of the First Tramway Line (Red Line) in Bologna – Italy	Municipality of Bologna	06/2022	04/2023	Detailed Design	3,123,214	331,577,463
Detailed design of the Fast Tram of Parco Nord Seregno – Italy	Ministry of Transport – Public Works Authority for Lombardy and Liguria	12/2013	12/2022	Detailed Design	3,770,000	124,345,126
Detailed Design of the Trolleybus of Genoa City – Italy	Municipality of Genoa	05/2021	08/2022	Detailed Design	5,987,654	470,000,000
Detailed Design of the Tramway between Rende and the University of Calabria in Cosenza – Italy	Calabria Region	09/2017	05/2020	Detailed Design	1,000,000	96,031,133
Trolley Bus Transport System in Verona - Italy	Azienda Mobilita' Trasporti Verona	07/2010	09/2018	Preliminary and Detailed Design	1,620,000	82,233,000

PROJECT	CLIENT	PERIOD		ACTIVITIES	COST OF SERVICES €	COST OF WORKS €
		FROM	TO			
Palermo metropolitan light railway – 1st line: Oreto-Notarbartolo – Palermo (Sicily), Italy	Municipality of Palermo	09/2005	05/2016	Preliminary Design, EIA	5,881,423	478,040,156
Light Rail 2B of Santo Domingo – Cable Stayed Bridge over Rio Ozama- Dominican Republic	Yellow Ingenieros & Arquitectos	05/2014	12/2014	Check of the Detailed Design, Wind Tunnel Test	328,619	50,000,000
Railway link from Bari town centre to Bari-Palese Airport - Italy	DEC – Degennaro Costruzioni – in association with IPA Precast	09/2008	06/2009	Detailed Design	700,000	52,212,000

Appendix A – Company’s Experience

Railways

PMC FOR THE IMPLEMENTATION OF THE RAILWAY LINK BETWEEN THE AIRPORT OF N'DJILI AND KINSHASA CENTRAL STATION

Location:	Kinshasa, DRC
Client:	Trans Connexion Congo Sarl
Services:	Feasibility Study, Preliminary Design, Detailed Design, Assistance in the Procurement of Works, Construction Supervision (under FIDIC Yellow Book)
Period:	05/2022 – ongoing
Construction cost:	Approx. Euro 250,000,000

Project Description:

In connection with the modernisation of the International Airport of Kinshasa, the governmental authorities have decided to implement a new electrified railway link to connect the airport to the Central Station in the city centre.

The railway link consists of 20.4 Km of standard-gauge main line and 8 stations, out of which two head-stations and 6 through-stations. The new trackwork is designed not only for passenger traffic but also for freight traffic, to allow for future link with the regional network.

The new railway is meant to replace the existing metric-gauge line which service was terminated in 2012 for safety reasons.

TECHNITAL is appointed as sole Consultant for the PMC, which includes all phases of design from Feasibility study through to Preliminary and Detailed Design, preparation of contract's documents and supervision of construction works according to FIDIC Yellow Book.



Kinshasa Central Station

The project includes the following components:

- Traffic Study
- Alignment
- Trackwork (permanent way) design
- Railway Operation Study
- Signalling
- Telecom
- Power supply and traction study
- Rolling stock study
- Structural design for railway civil works
- Architectural/Structural/MEP for buildings
- Geotechnical design
- Hydrological/Drainage design
- Specifications for geotechnical and topographic surveys.

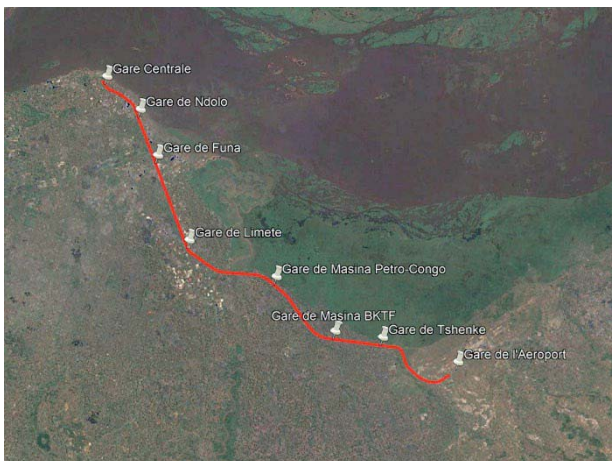

DETAILED DESIGN OF ALIGNMENT AND PERMANENT WAY OF THE HIGH-SPEED RAILWAY LINE FROM EL AIN EL SOKHNA CITY ON THE RED SEA COST TO MARSA MATROUH ON THE MEDITERRANEAN COAST

Location:	Egypt, Governorates of Suez, Cairo, Giza, Matrouh
Client:	JV Orascom Construction S.A.E. and The Arab Contractors (Osman Ahmed Osman & Co.)
Services:	Detailed Design of Alignment and Permanent Way
Period:	03/2022 – Ongoing
Construction cost:	Euro 600,000,000

Project Description:

The High-Speed Rail "Green Line" is the Egypt's first-ever high-speed rail line. It will connect the port cities of Ain Sokhna on the Red Sea and Marsa Matrouh on the Mediterranean Sea, passing near Cairo and the New Administrative Capital located 30 miles east of Cairo, for an overall length of 660 km.



Main technical features of the project: track form ballasted continuous welded rails tracks, double-track main line 660 km length, max. speed for passenger trains 250 km/hr, max. speed for heavy freight trains 120 km/hr.

The project includes 20 stations, one main depot and two stabling yards. The line is expected to transport more than 30 million people a year and to reduce the travel time by up to 50%.

The Green Line is the first line of the Egyptian high-speed rail network which will be developed as a state-of-the-art integrated rail system with a high-speed, fully electrified main and freight rail line. The rail system will feature the latest technology and comply with European standards.

The services provided regard the Detailed Design (approved for construction) of Track Alignment and Permanent Way after review of the Preliminary Design and include: horizontal and vertical alignment for double-track high-speed line, main depot and stabling yards, technical specifications for track components, technical support for identification of ballasted/unballasted sections, calculation of track stiffness and deformations, design of guard-rails, wheel-rail interface study.



DETAILED DESIGN OF THE DOUBLING OF THE ROMA-VITERBO RAILWAY – SECTION RIANO CASTELNUOVO DI PORTO

Location:	Italy, Rome
Client:	ASTRAL S.p.A.
Services:	Detailed Design (issued for construction); Project Management.
Period:	09/2022 – ongoing
Construction cost:	Euro 48,920,325

Project Description:

The project envisages the doubling of the Riano – Morlupo section of the Rome-Viterbo extra-urban railway line including some variants. The upgrade is on the same site except for few variants. The upgrading of the railway line is accompanied by a series of interventions on the road network aiming at eliminating the existing level crossings and at maintaining the functional continuity of the road network.

The work on the section is part of the on-going modernisation of the railway and is aimed at improving the transport service for the northern part of the Province of Rome by a railway line characterised by a metropolitan frequency and serving the catchment area of the northern part of the Municipality of Rome, but also a number of smaller towns such as Capena, Castelnuovo di Porto, Morlupo and Riano.

The implementation covers:

- civil works
- automatic control system
- electric power and traction systems,
- signalling/safety systems,
- telecommunication systems,
- MEP
- ticketing system
- anti-intrusion and video-control

The technological items are an extension of the same systems already in place for the rest of the line.

Lot 1 line is 3.6 km long, of which approximately 1 km is in a cut and cover tunnel.

The project has been developed with the following features:

- Minimum radius increases to 275m such as to ensure design speeds of 80km/h;
- Doubling of the track alongside the existing track and track adjustments to eliminate curves with radii below the minimum established threshold, without departing excessively from the existing track;
- Track variants with the construction of major works where it is not possible to double or rectify due to the presence of buildings or the particular orography of the terrain: it's envisaged the construction of 2 viaducts and 2 tunnels.
- Elimination of existing level crossings and by modifying the road network;
- Improvement of the plano-altimetric layout using parabolic and vertical junctions with a radius of no less than 3000m for $V_p=80$ km/h and 2000m in the initial section with $V_p=60$ km/h;
- 4.00m spacing between the two tracks as required by the standards of Italian National Railways;

In the sections of railway track in question, 2 viaducts are included ($L=103.46$ m and $L=103.23$ m);

The deck of both viaducts consists of mixed steel-concrete structures with single-supported beams and span of 32.75m.

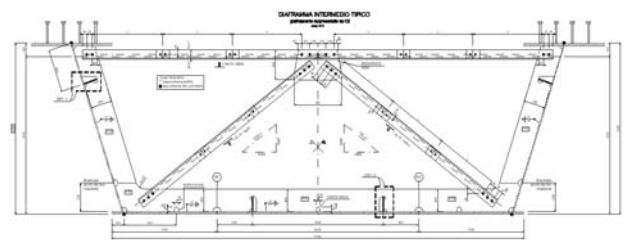

Two tunnels are planned on the section of railway line in question, subdivided as follows:

$L=388$ m, in three parts:

- from km 1+627 to km 1+892 ($L=265$ m) – Cut and cover tunnel;
- km 1+892 to km 1+970 ($L=77$ m) - Natural tunnel;
- km 1+970 to km 2+016 ($L=46$ m) - Cut-and-cover tunnel.

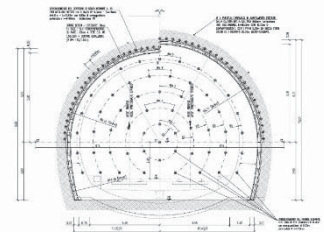

$L=705$ m, divided in two parts as follows:

- km 2+496 to 3+034 ($L=536$ m) – Cut and cover tunnel;
- km 3+137 to 3+304 ($L=167$ m) – Cut and cover tunnel (between the two sections the new underground station of Castelnuovo di Porto has been designed).

For cut and cover tunnels the "top-down" construction method has been preferred.

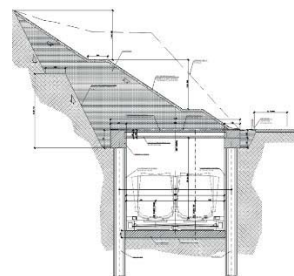

The project envisages the burying the platforms of Castelnuovo di Porto station, preserving and adapting the existing building, constructing a new technology building, and building two canopies, one glazed to house the exit turnstile between the two buildings (the existing and the new technology building) and a metal one to protect access to the underground area of the

station. The project also covers the access road to the station itself and the perimeter of the areas to be used for parking cars.

The project also includes the construction of a multi-storey car park next to Castelnuovo di Porto station.

Two primary requirements were taken into account in the design: the construction of a new car park to serve commuters and residents and the creation of a new road system, in order to optimise the traffic from the station towards the city and requalify the area in question from an urban and environmental point of

The project walls are normal reinforced concrete structures, prefabricated in the factory. They consist of a succession of modular panels 2.50 m wide, full height, provided on the ground side with a stiffening rib extending from the base to the top. They are then anchored to the in-situ foundation slab.

The envisaged walls are covered by panels covered with local stone for landscaping and environmental integration.

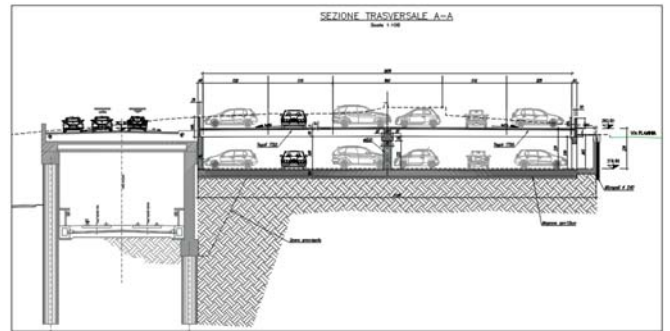
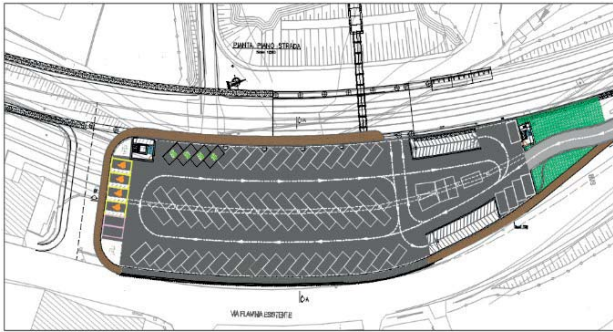

view.

The car park is accessible both from the SS3 Flaminia National

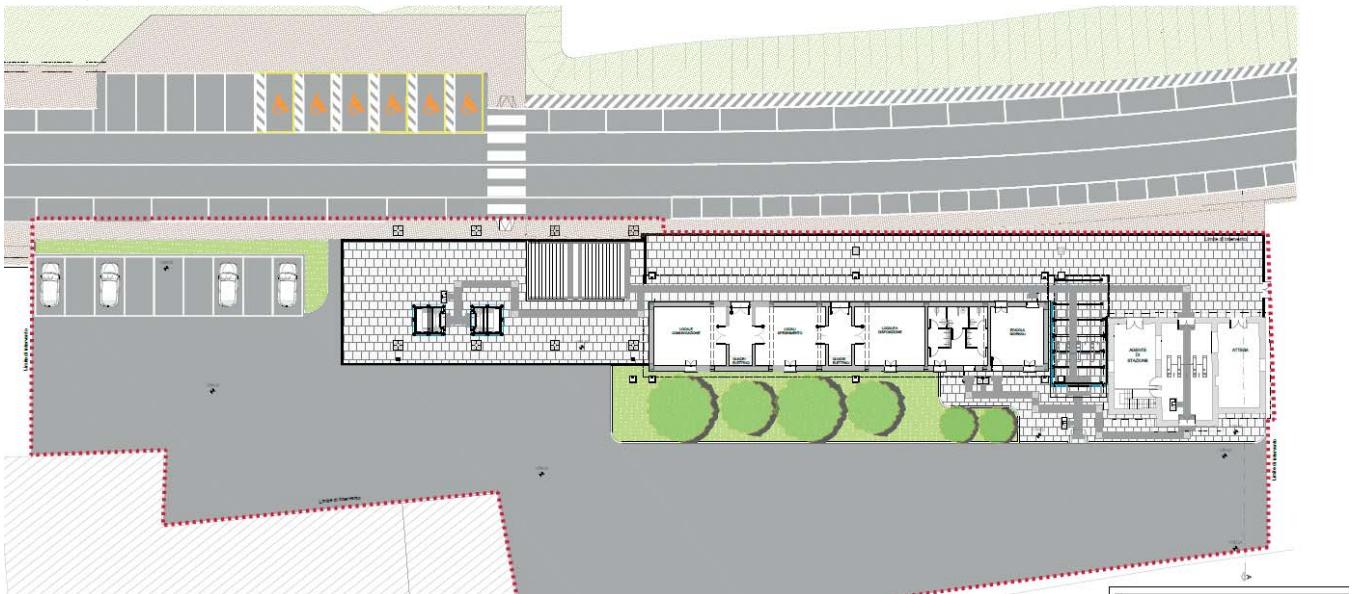

Road coming from Mortupo and from the new project road system.

Taking into account the highly anthropized territory, it emerged the need to foresee several sections of retaining works to limit the land occupation for the new railway line. Some of the structures are built with retaining walls, others with bulkheads made of Ø800, Ø1000 or driven micropiles.

CONSTRUCTION OF THE SECOND TRACK AND CONSTRUCTION OF A NEW DOUBLE TRACK LINE ON THE RAILWAY SECTION HRVATSKI LESKOVAC – KARLOVAC

Location:	Hrvatski Leskovac – Karlovac, Croatia
Client:	Croatian Railways Infrastructure Ltd
Services:	Feasibility Study, Preliminary Design, Detailed design
Period:	11/2012 – 01/2021
Construction cost:	Euro 315,000,000

Project Description:

The project area lays in the Northern part of Croatia, between the flat region of the Sava river, near the City of Zagreb, and the Kupa river, near the City of Karlovac. The job consists in the upgrading of the existing single track line to a double track line between the cities of Hrvatski Leskovac – Karlovac.



It is a constituent part of the future railways transport corridor R3 State border Hungary/Croatia, Koprivnica, Dugo Selo, Zagreb, Karlovac, Rijeka, State border Croatia/Slovenia and it is part of the most important national railway line, because it links the capital city of Zagreb with the most important Croatian port, Rijeka.



The Preliminary Design of the new double Track Line on Railway Section Karlovac-Leskovac was delivered on November 2013. In October 2014, as a consequence of Jasper's request, a series of alternatives design solutions, relevant to different alignments hypothesis have been studied.

The new project alignment for the Main Design has been developed after the study of "Comparative analysis among alternatives for the rehabilitation and doubling of the railway line. studies of alternatives", according to the request of the Client, after including Jasper's observations.



The overall work between Hrvatski Leskovac and Karlovac has been divided into 2 Section:

- Section I: Hrvatski Leskovac (included), 8+386 – Jastrebarsko (included), 33+292;
- Section II: Jastrebarsko (excluded) 33+292 – Karlovac (included), 54+228;

The upgrading works will be carried with the construction of a second track adjacent to the existing one for the entire length, which is characterized by viaducts and embankments with heights ranging between 1 – 6 m. Along the alignment new underpass and overpass will be built, as well as stations, stops, culverts and other civil works.



The overall procedure of approval lasted several months and the project was subject of several time extensions.

DETAILED DESIGN OF THE NEW TRENITALIA CURRENT MAINTENANCE CENTRE IN “TURIN SORTING CENTRE” IN THE CITY OF TURIN

Location:	Italy
Client:	Vianini Lavori S.p.A. (Contractor) for Italferr S.p.A. on behalf of Trenitalia S.p.A.
Services:	Detailed architectural and structural design, geological geotechnical and environmental studies, drainage system design, construction areas design and scheduling.
Period:	09/2014 – 04/2017
Construction cost:	Euro 124,895,000

Project Description:

The Project of the New Trenitalia Current Maintenance Centre in “Torino Smistamento”, in the city of Turin, is included in Trenitalia S.p.A. plan of investment, in order of a continuous modernization of its rolling stock maintenance centres. Particularly Trenitalia aim is to invests in Turin site development in order to create a strategical node for further train circulation and maintenance in the European railway network. In the New Centre will be maintained either regional service trains or the AV trains ETR 500 and ETR 1000. In detail the principal goals of the modernization of the actual Maintenance Centre in Torino Smistamento are:

- Maximum reduction of duration and cost of the train's layover for the operations of maintenance;
- Minimization of the interferences with rail traffic on ordinary and AV railway network;
- Optimization of production;
- Modernization of equipment to increase efficiency and decrease environmental impact during maintenance operations;
- Increase the safety of men at work.

The overall work site surface is 270.000 m² and the new configuration consists in a new central maintenance building of 23.000 m² for current maintenance operations, an adjoining building of 12.500 m² for internal carriages cleaning and a third building of 3.500 m² for external carriage cleaning and maintenance operations on wheel axles, by the underground lathe machine. It's also included a new building for directional and technical services with overall length of 550 m, variable width, and maximum height of 16 m for 3 floors. The superior floors will host directional and representative offices, while in the lower floor will be realized a warehouse to store technical materials and plants, and many workshops for technical interventions. The whole buildings will be realized with metallic principal structure and precast completion elements. The project includes the geometrical and technical design of the internal railway tracks, necessary for the internal train's movement and access to the different buildings, and the design of technological railway and building plants either for principal buildings or for minor buildings located in rest of the area.

The design development process is articulated in the following phases:

- Definition and execution of the geological, topographic and environmental surveys plan. The environmental surveys, which aim was to investigate the quality of in situ underground terrain and existing ballast, revealed the presence of asbestos in underground terrains and consequently has been defined all the procedures to manage the material in safety conditions;
- Definition of the project work phases sequences and scheduling, in order to permit the contemporary exercise and services of the existing parts of the centre, while the new buildings are under construction;
- Detailed and executive design of architectural and structural elements, railway tracks, technological plants (electric, mechanical, signalling and telecommunications), external completions works (design of an internal work site roadway and squares, drainage networks);
- Construction areas design, safety work site coordination design (according to Italian Law D. Lgs. 81/08), detail works scheduling.

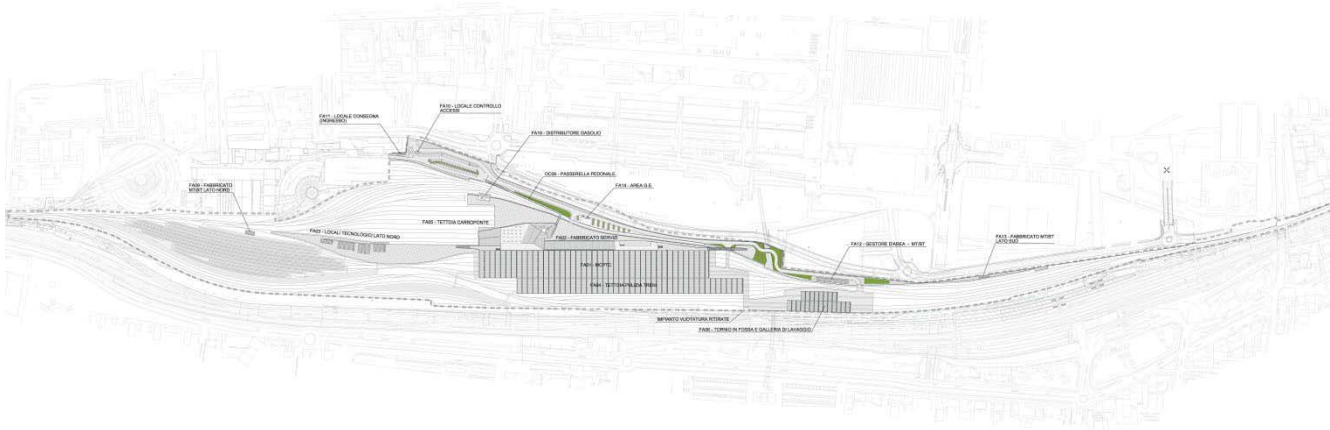

DEVELOPMENT OF THE NATIONAL MASTER PLAN FOR RAILWAY OPERATIONS AND MAINTENANCE (O&M), LEGAL FRAMEWORK, MANAGEMENT SYSTEM

Location:	Ethiopia
Client:	ERC – Ethiopian Railways Corporation
Services:	Master plan, railway operation and maintenance guidelines, specifications, draft railway legal frameworks and regulations, capacity building, preparation of budget planning schedule
Period:	01/ 2014 – 07/2017
Construction cost:	Euro 12,5 billion

Project Description:

The scope of the consultancy services is to prepare a strategic master document that shall be used by the Ethiopian Railways Corporation (ERC) to develop an integrated and efficient railway transport system in order to ensure competitive, safe and reliable rail transport for freight and passengers with an affordable tariff structure, and to perform capacity building to the Operations and Services Division of ERC.

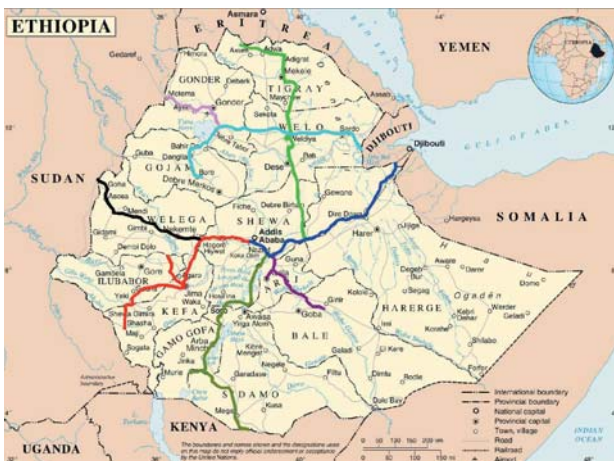

Description of the activities:

As the first task of the Study, a Railway Transport Master Plan for Operations and Maintenance was prepared, to identify routes and corridors for railway lines that would provide connectivity to main centres of commerce and trade in the country, as well as to other countries in the region. This task includes: transport demand analysis with traffic forecast until year 2043, technical study and cost analysis, cost benefit analysis and project prioritization through ranking of key projects.

The Ethiopian Railways network object of the study is 4,500 Km. No. 8 rail lines were considered involving a total investment of 20 US\$ billion : 16 for infrastructure and 4 for rolling stocks. Ethiopian rail network besides connecting all main cities is aimed to connect Ethiopia with neighbouring countries: Djibouti, Sudan, South Sudan and Kenya.



The last part of the Master Plan focuses on the capital Addis Ababa and its crucial role in the transport network of the Country (Addis Ababa junction). Objectives of the strategic planning are to support and concentrate urban development enhancing Addis Ababa Hub, provide an efficient and well located urban-railway interface, guarantee an efficient rail mobility within the Country (NRN) and its Capital (LRT), reach foreign harbours, connect main Addis Ababa –Bole airport ADD.

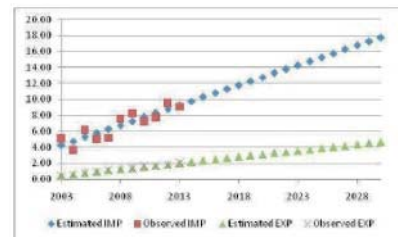
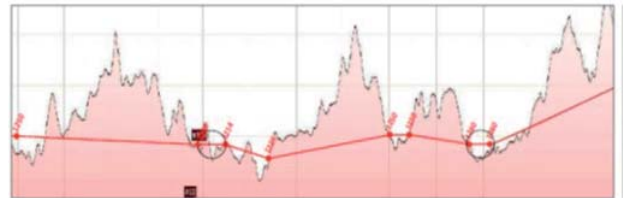

The other tasks of the Study include: preparation of Railway Operations and Maintenance Guidelines incorporating the best practices which have been successfully implemented in similar contexts, prepare Railway Operations and Maintenance (O&M) Specifications, Draft Railway Legal Framework and Regulations, development and conduction of a Training Programme to build the capacity in the railway sector, preparation of a Budget Planning Schedule to develop guidelines and priorities for each fiscal year to guide expenditures for operations and maintenance so as to achieve the greatest outcome of the system.

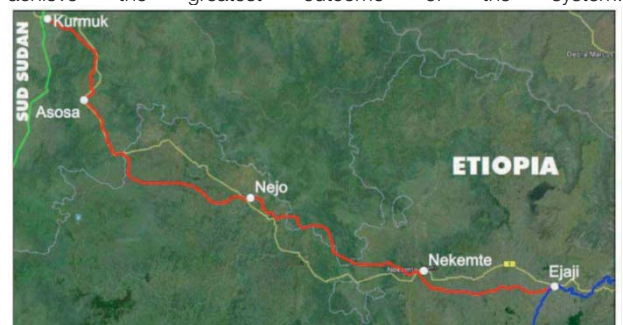

HIGH SPEED RAILWAY LINE MILAN-BOLOGNA: RELOCATION OF THE EXISTING LINE IN THE PROVINCE OF MODENA (LOT 4.A)

Location:	Modena, Italy
Client:	Grandi Lavori Fincosit – Rome, for Cepav Uno consortium
Services:	Final and detailed design, technical assistance during construction
Period:	06/2004–12/2016
Construction cost:	Euro 90,210,070

Project Description:

Within the concession for the implementation of the Milan-Bologna High Speed Line, assigned to CEPAV UNO Consortium (of which Grandi Lavori Fincosit S.p.A. is a member) by the public company T.A.V. (Treno Alta Velocità - High Speed Train Authority), TECHNITAL has carried out the final and detailed design of the works on the existing Milan-Bologna railway line in the Province of Modena (Lot 4.A "Modena").

The project regards the relocation of the existing Milan-Bologna railway line outside the Modena municipal boundaries, the doubling of the existing Modena-Mantua line for the connection to the high speed line, and the branch line for freight trains to these lines, for a total length of new line of approximately 13 km.

The relocation of the existing railway regards a stretch of about 10.8 km, starting from Modena station towards Milan, with connection to the existing line west of the town of Cittanova. The freight line Villanova-Marzaglia branches off the Modena-Mantova line south of Secchia river bridge and links to the relocated Milan-Bologna line and to the third freight track. The third freight track runs from the freight yard located on the south-east side of the Milan-Bologna line, and links up with the freight line Villanova-Marzaglia, to the north-west of the Milan-Bologna line, underpassing by a bored tunnel, the cut and cover tunnel of the Milan-Bologna line. This layout avoids the transit of freight trains, travelling along the Cittanova-Villanova or Cittanova-Modena routes, on the relocated section of the Milan-Bologna railway.

Activities performed include: study of horizontal and vertical layout of the infrastructure, design of structural works (viaducts, cut and cover tunnels, box culverts and underpasses, retaining walls, etc.), geotechnical studies, hydraulic and hydrological studies, design of road links and related structures. Among major works are a 2 km long cut and cover railway tunnel under the A1 highway, and a cut and cover tunnel on the "SS9 Emilia" national road.

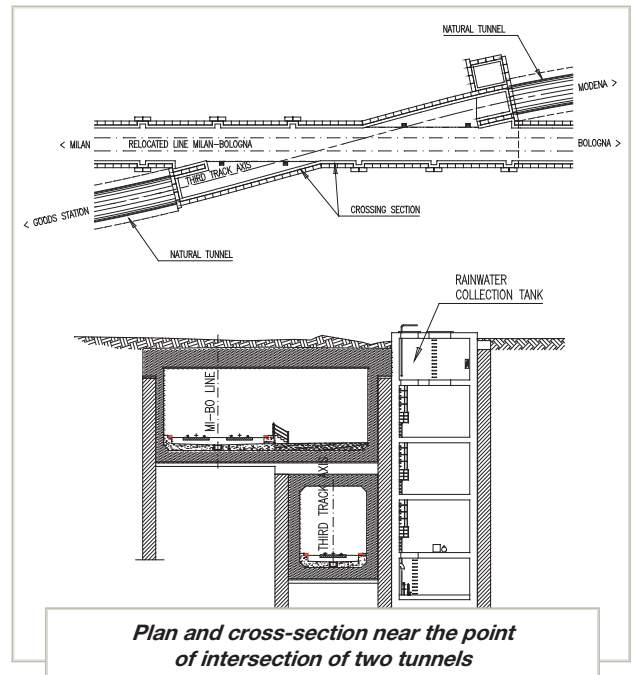

The new line runs through a rural area, scarcely urbanized, particularly valuable from the historical and environmental point of view due to the presence of archaeological sites of the Roman Age in the surroundings of the existing "SS9 Emilia" national road, and of two historic villas (Villa Luppi-Messerotti and Villa Gaudenti).

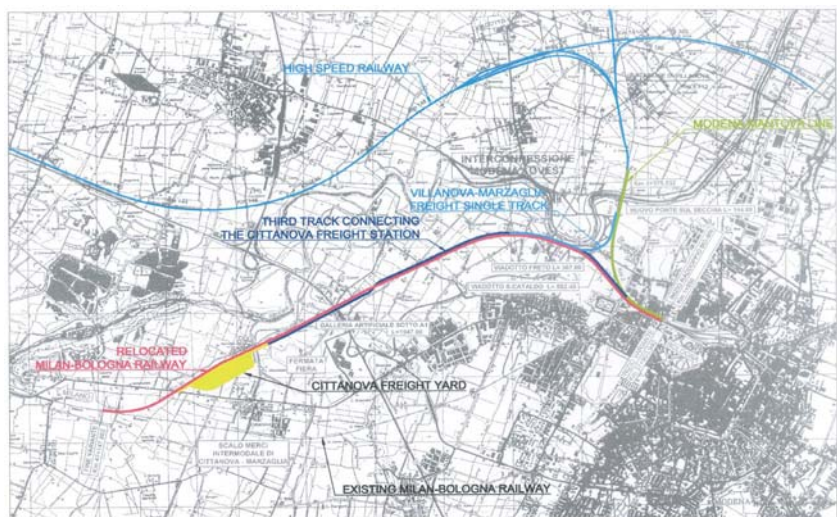

PRELIMINARY DESIGN OF INTERVENTIONS FOR THE COMPLETION OF MODERNISATION PROGRAM OF THE CIRCUMETNEA RAILWAY LINE

Location:	Sicily, Italy
Client:	Ferrovie Circumetnea
Services:	Preliminary design and environmental impact study
Period:	10/2009–07/2016
Construction cost:	Euro 1,325,693,754

Project Description:

The existing railway was built at the end of 18th century, almost entirely circling the volcanic cone of Mount Etna and climbing mountain slopes up to about 1,000 m above sea level, whereas the clockwise train departure and arrival stations, respectively the Catania Borgo south side terminal and the Riposto east side terminal, are both at sea level, on the east coast of Sicily.

In Giarre station, 1.5 km before Riposto terminal station, the line is connected with the Messina-Catania main line, whilst in Catania Borgo terminal station it connects with the Catania underground metro line, currently reaching Catania Galatea station through 2 intermediate stations and linked to Catania railway station and the port. The Catania Borgo - Riposto line is in fact about 100 km long, still narrow (1 meter) gauge and not electrified (diesel traction). Due to narrow curves (many of them are 100 meter radius) and high gradients (in many sections reaching 4%) the commercial speed of the trains does not reach 35 km/hour.

The aim of the project is to improve the level of service (design speed is 120 km/h), thereby increasing passenger traffic, and use of the public rail transport system instead of the private one by road. Another significant goal of the project is to eliminate the existing road level crossings, by overpassing or underpassing the line. Thus the Client has planned a long term modernization program, envisaging the transformation of the line partially into double track and entirely with ordinary gauge and electrification, mainly along a new route as a variant and/or alongside the existing line, and in particular the following interventions:

- Automatic train control (ATC) system along the urban stretches Catania Stesicoro – Catania Borgo and the suburban ones Misterbianco Centro – Paternò – Adrano (approx. 40 km)
- Doubling and electrification of the track along the stretch Misterbianco Centro – Paternò (18.5 km)
- Transformation to ordinary gauge and electrification along the stretch Paternò – Adrano (18 km), where civil works have been already executed by the Client
- Modernisation, transformation to ordinary gauge and electrification along the stretch Adrano – Randazzo (approx. 30 km)
- Modernisation, transformation to ordinary gauge and electrification along the stretch Randazzo – Riposto (approx. 38 km)

Among the services carried out is a Transportation Study, based on the analysis by means of a mathematical simulation model of the functioning of the system with several alternatives of both demand for mobility and project solution (infrastructure and/or operating), through various implementation phases.

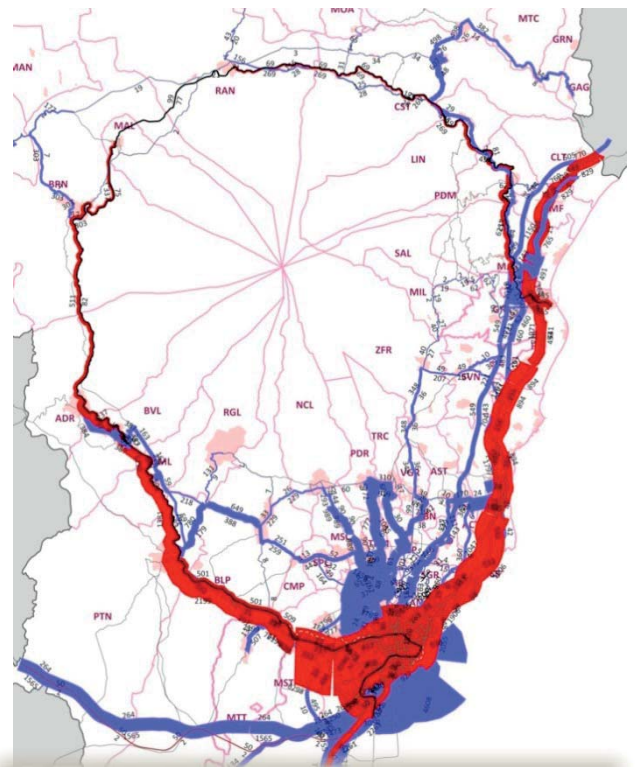

Traffic flows along the transportation study network

The transportation study was conducted on 4 different design alternatives, selected so as to minimize the impact on the environment and the area.

The alternatives studied are characterized by 2 different configurations of the track infrastructure, which determine travelling time of the line, combined with 2 alternatives in terms of operation (frequency).

inally the new design alignment has been selected, also defining the train crossing points and the train stops. Based on infrastructural aspects and relations with the area, the optimal design option has been selected as the alternative in which the section Misterbianco - Paterno is double track and the section Adrano - Randazzo is upgraded with a "fast" track alignment provided by "high" frequency service..

Among the services carried out is also an Operating Model based on a simulation using the OPENTRACK software, both of a single train run as well as the trains circulation along the line according to predetermined frequencies and/or under conditions of minimum time between successive trains

Moreover, a Cost-Benefit Analysis (Economic and Financial) has been performed, as well as an Economic and Financial Plan for various financing hypotheses via public contribution.

The preliminary design has been split among the associated companies, TECHNITAL being in charge of the longest section, namely Randazzo-Riposto, almost 40 km long and the most critical in terms of both horizontal and vertical alignment, as well as the section with most of the tunnels and viaducts. In fact, the preliminary design of this section includes a total of 40 tunnels and viaducts, as well as around 30 over- and underpasses to eliminate level crossings and to maintain the present road connections interfering with the line.

Retaining the same locations for the existing stations, although 2 of them will be underground rather than at ground level, TECHNITAL studied various alternatives of new line, characterized by different minimum curve radius and consequently line speed.

The Preliminary Design included in particular the following activities, in accordance with current legislation:

- geological/geotechnical and hydrological/hydraulic study; geognostic surveys /laboratory tests and archaeological site investigations,
- plano-altimetric layout (200 m minimum curve radius, 4% maximum gradient) based on new aerial mapping, for 3 alternatives and for the selected design option, assuming continuity of operation (temporary adjacent track);
- track equipment (ordinary gauge),

- station plans (circulation/siding tracks),

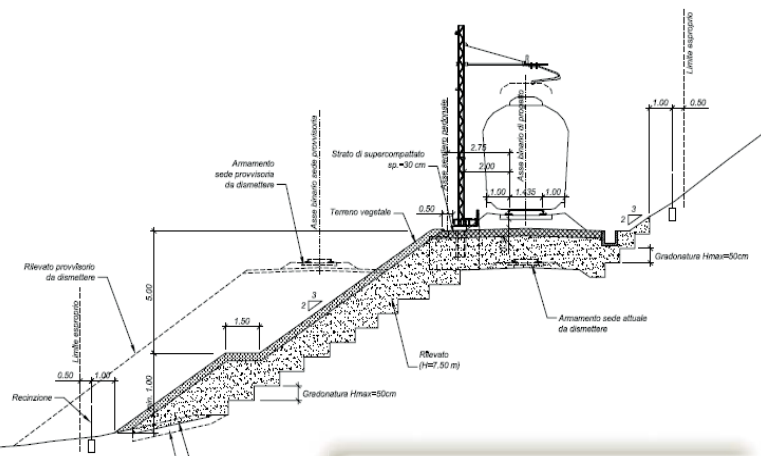

Railway typical cross section

- major works (tunnels – maximum length 1,750 m / viaducts – maximum length 150 m) and minor works (overpasses/underpasses/hydraulic crossings);



Viaduct "Brancatello" – Current



Viaduct "Brancatello" - Proposed

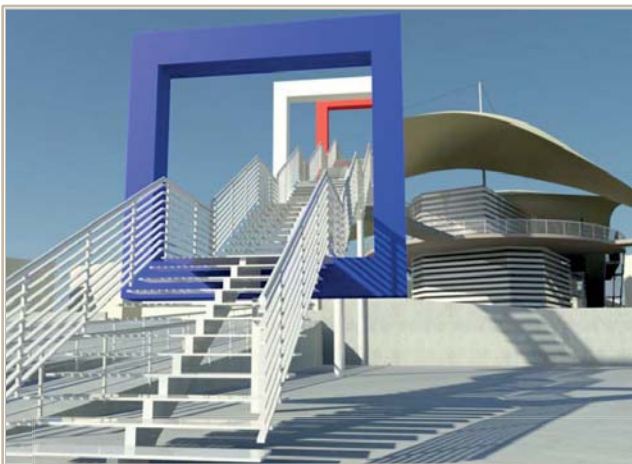

People Mover Riposto Terminal and pedestrian access to the Marina

- automatic control system (ATC) along the stretch Catania – Adrano (approx. 40 km)
- electric power and traction systems,
- signalling/safety systems,
- telecommunication systems,
- interference with public utilities and areas to be expropriated/occupied,
- work sites and construction lots
- construction cost estimate, on the basis of parametric prices for earthworks and structures

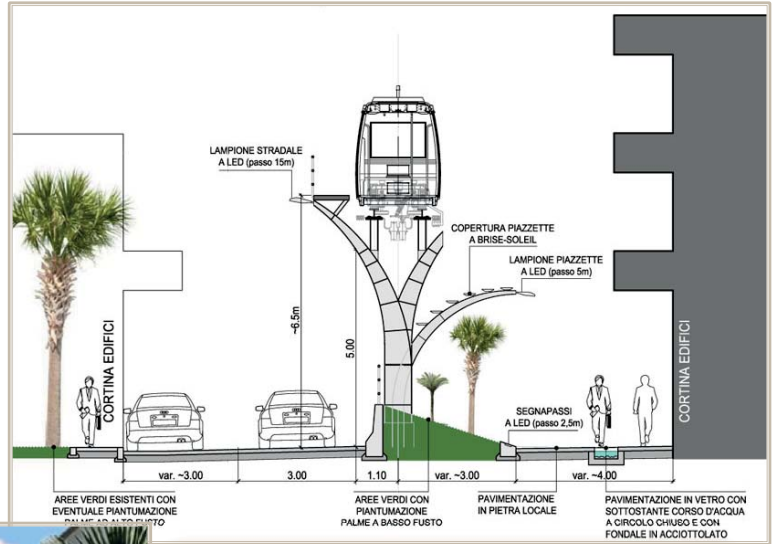

Giarre-Riposto people mover elevated section with urban development

The designed people mover system consists of a rail-mounted vehicle with rope traction that runs at ground level in the first section and elevated in the second section. In particular, the People Mover has been designed by TECHNITAL between the stations of Giarre and Riposto as an alternative to the final stretch of the railway line running through an urban context.

Taking into account the urban development in the area crossed by the elevated people mover, it is expected that the current two lane road, for residential use and with limited roadside parking space, will be converted into a one-lane vehicular road, for the remaining part reserved to pedestrian use.

Among the services provided is also the preliminary design of the links of the Circumetnea line with the Messina-Catania line of Rete Ferroviaria Italiana (RFI), in the Catania Central and Giarre stations.

Moreover, the project includes the preliminary design of the People Mover type transport system branches to the Circumetnea line at 3 stations.

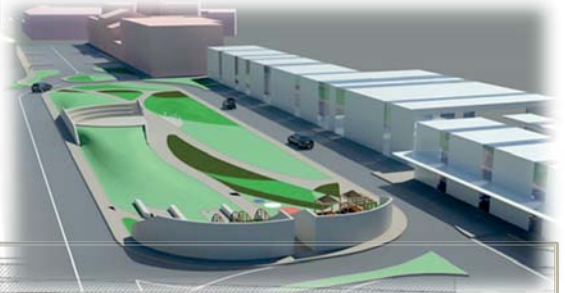

Giarre Station interchange area: MAP and 3D view

MALPENSA AIRPORT - T2 LINK-UP NEW RAILWAY STATION AT TERMINAL 2 (Lot 1) AND RAILWAY LINK T1-T2 (Lot 2)

Location:	Milan, Italy
Client:	SEA S. p. A. (Lot 1) - Nord Ing S.r.l. (FERROVIENORD Group) (Lot 2)
Services:	Final Design of the new underground railway station and railway link between Terminals 1 and 2 (Lot 2). Final design of civil works, mechanical, electrical and plumbing services for the station, geological and geotechnical studies, utility diversions, site layout planning, preparation of tender documents.
Period:	04/2012 -07/2013 07/2015 (Addendum Lot 2)
Construction cost:	Lot 1: Euro 49,020,000 - Lot 2: Euro 43,422,700

Project Description:

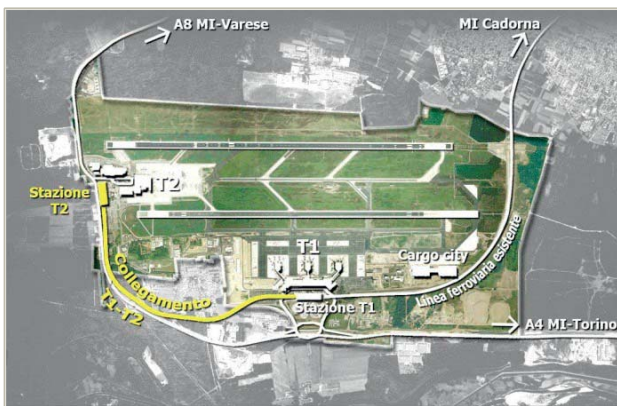

The Lot 1 project regards the new underground railway station at Terminal 2 of Milan Malpensa Airport, with a 2-level car park located above the station, connected by a pedestrian link to the passenger Terminal 2.

The station is the terminus of the new railway link between Terminal 1 and Terminal 2 (Lot 2) and it is designed (both structures and services) to be transformed in a crossing station to allow for future link with regional network.

The station comprises four levels: platform level for 4 rail tracks, under which tunnels for technical and emergency services are located; concourse level dedicated to passenger services and power substations. These underground levels are made of partially prefabricated concrete structures (both cast-in-situ and prefabricated).

In addition there are two levels above ground, which are destined to car park for passengers, constructed with steel structures.

Due to vicinity of buildings, existing roads and utilities, excavation works are carried out by large use of diaphragm walls.

Large steel structured light cannons lead natural light to concourse and platform level.

The implementation covers:

- civil works
- automatic control system
- electric power and traction systems,
- signalling/safety systems,
- telecommunication systems,

The Lot 1 includes a new pedestrian link to the air terminal with a shelter made of complex steelwork with glass cover.

Mechanical electrical and plumbing services are included in the design:

- mechanical and ventilation systems
- water supply and fire-fighting installations
- special electrical systems
- lighting and motive power systems for line and stations
- earthing system
- cableways for the system installations
- fire detection system.



The Lot 2 project regards the double-track railway link T1-T2 of a total length of 3.15 km which develops entirely below the ground level. It includes No. 5 cut-and-cover tunnels for a total covered length of 998 m. The tunnel construction method is different based on the surface constraints: either top-down method with r.c. pile walls or prefabricated or cast in place structures within open excavation.

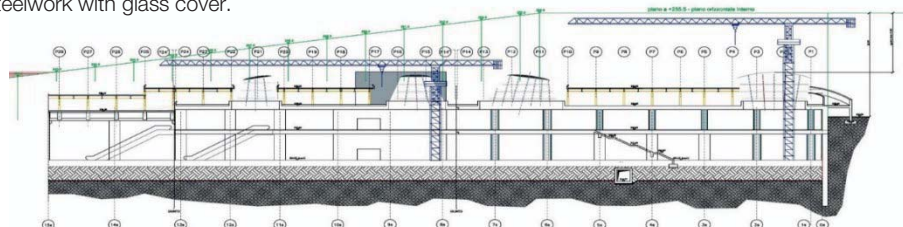

HIGH SPEED RAILWAY LINE MILAN-BOLOGNA: DESIGN AND CONSTRUCTION OF A SECTION IN THE PROVINCE OF PIACENZA (LOT 1.4, TOTAL LENGTH OF APPROX. 28 KM)

Location:	Piacenza and Modena, Italy
Client:	Grandi Lavori Fincosit - Rome
Services:	Final and detailed design, technical assistance during construction during construction
Period:	08/2001 – 12/2010
Construction cost:	Euro 242,431,000

Project Description:

The project regards the design of all the civil works related to the new high speed railway line and the branch lines included in the Lot 1.4 "Piacenza" constructed by the contractor Grandi Lavori Fincosit, including viaducts, underpasses and fly-overs, hydraulic works and auxiliary roads and buildings, as well as landscaping works. In particular, the project includes:



- 7 railway viaducts with prestressed decks and in mixed steel/concrete structures, among which the "Piacenza" viaduct 5.1 km long;
- 1 cut-and-cover tunnel for the railway;



- railway embankment sections of various heights;
- box culverts of various dimensions to allow the continuity of traffic flows and water courses interfering with the line;
- 12 multi-span fly-overs overpassing the railway with prestressed decks or mixed steel/concrete structure;



- buildings for technological systems;
- stream and water channel hydraulic control works;
- 4 road links, among which the Piacenza beltway nearly 7 km long including major structures;
- Landscaping works.



MESSINA-PALERMO RAILWAY LINE: ROMETTA-PACE DEL MELA SECTION

Location:	Sicily, Italy
Client:	Italferr
Services:	Preliminary, final and detailed design, works supervision
Period:	07/2002–09/2009
Construction cost:	Euro 41,882,800

Project Description:

The project takes place within the province of Messina in an area limited by the cities of Tracoccia in the north and Venetico Marina in the south and characterized by a slope which on the 12th of September 2001 was subjected to a landslide which affected the RSU dumpsite at the base of the hill.

At the time of the slip, the contracting Company was excavating the Sciannina-Tracoccia tunnel which was being bored contemporaneously from the Messina side and from the Palermo side. Some 156 metres of natural tunnel had already been bored from one side and 381 meters from the other, which meant that 110 metres were missing to complete the boring, which has a total length 647 m. The upheaval destroyed the part of the Scianina-Tracoccia tunnel bored from the Messina side which therefore needs to be reconstructed, possibly according to the same horizontal and vertical layout, so that the various almost-completed works (like viaducts and tunnels) located above and below this point can still be used.



The landslide also damaged the RSU dumpsite (which was in the post-mortem management phase) which presented the surfacing of refuse, the discharge of percolated liquid and the destruction of the existing systems for capturing both this percolated liquid and biogas.

The project consists of two parts: the study of all the works required to restore and secure the slope affected by the 2001 landslide and the dumpsite located at its foot, and the study of the works needed to complete the Sciannina-Tracoccia railway tunnel on the Palermo-Messina double-track line in the same position foreseen in the original design. These include the construction of the tunnel mouth on the Messina side where the natural section starts, the excavation of the area affected by the landslide and of the part still to be excavated, and the casting of the final cladding on the 20 m section on the Palermo side after the preliminary cladding has been secured with some urgent works.

Between Km 4+461.00 and Km 4+730.00, where the landslide occurred and where the RSU dumpsite is located, the works consist of the restoration and the re-shaping of the mountainside to guarantee long-term stability in line with the

existing laws. To achieve these works, the project must first secure the RSU dumpsite in accordance with the current laws so as to guarantee its post-mortem management. The cleanup and the definitive making safe of the dumpsite must be carried out before any new slope stabilization work and also to ensure the continued neglect of the dumpsite does not cause further serious environmental damage.



In fact, between Km 4+461.00 and Km 4+730.00, the tunnel had been bored working from the Palermo side but only the preliminary cladding had been completed. Subsequently, considering the necessary long interruption of the works, it was decided to cast a r.c. coating on the face with a big slab at the base and an additional 0.30 m of spritz on the preliminary cladding.

Between Km 4+351.00 and Km 4+461 the tunnel had not been bored, and therefore the works will need to be done in the non reworked terrain. From Km 4+461, which corresponds to the tunnel entrance on the Messina side, the boring works will have to be carried out in ground which has been heavily reworked by the landslide and by the collapse of part of the tunnel. Between Km 4+634.70 and Km 4+722.90, the underground work will be completed with realization of the artificial section and the portal.

Once the tunnel has been completed, the re-modelling of the slope will be finished, to cover all the sheet-piling on the uphill side and make possible the green works and the environmental recovery of the area.

The project also includes various other works such as the re-modelling of the adjacent quarry area, the securing of the slope affected by the landslide at the tunnel entrance on the Palermo side, the realization of the bridge over the Macria stream with a span length of about 16 m, and the completion of the railway line between the Palermo side of the Martillato tunnel and the Messina side of the Scianina-Tracoccia tunnel. Following the decision to eliminate the Venetico station, originally foreseen in this location, this will be just an ordinary line section in a cutting.

INTERNATIONAL AIRPORT OF MILAN MALPENSA - NEW CARGO APRON

Location:	Milan, Italy
Client:	S.E.A. S.p.A.
Services:	Detailed design
Period:	06/2006 – 01/2008
Construction cost:	Euro 12,900,000

Project Description:

The project works regards a new underground railway tunnel for the new Cargo City at Malpensa Airport in Milan (Italy).

The whole tunnel has a length of 626 m, is totally curve with a radius of 1,200 m and has a double-track railway line. The first section 141m long falls in the "land side" of the airport and is designed for "road load; the subsequent section 485m long falls into the "air side" and are designed for "cargo aircraft loads". The tunnel roof has a box section, with internal width of 15.60 m and a minimum height of 6.1m above the rail. The width is greater than the minimum required for the double track in order to allow for the execution of the excavations and foundations, without interfering with the rail traffic.

The works consist of:

- Detailed design (structures and finishing) of a new underground railway tunnel of the new cargo city.
- Detailed design of Technological passageway of technical networks, water, sewer, and fire protection to interface with the existing tunnels and other pre-existing works.
- Earthing Network.
- Geotechnical investigations needed for the design and geotechnical Report.
- Automatic control system, signaling/safety, telecommunication, electrification and traction.

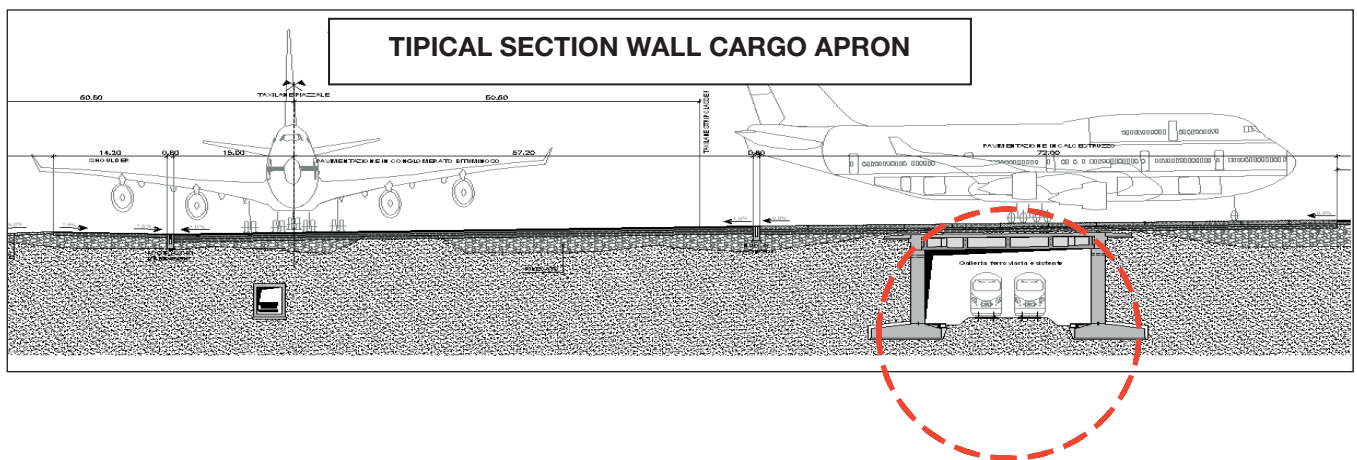

DETAILED DESIGN OF THE TRAMWAY RENDE - THE UNIVERSITY OF CALABRIA IN COSENZA

Location:	Cosenza - Italy
Client:	Cooperativa Muratori & Cementisti C.M.C. - Ravenna
Services:	Detailed Design
Period:	05/2016 – 05/2020
Construction cost:	Euro 96,031,133

Project Description:

The detailed design of the tramway between Rende and the University of Calabria in Cosenza concerns mainly the construction of a tramway line on existing urban roads, with the exception of the section connecting the University of Calabria, which is extra-urban link. Besides the main line between Rende and the University of Calabria, there are 2 other spurs for the Hospital and for the workshop/deposit in Vaglio Lise.

The three sections (both single and double track) are integrated and represent a single urban mobility system. The total length of the track is about 17 km (16.893 km)

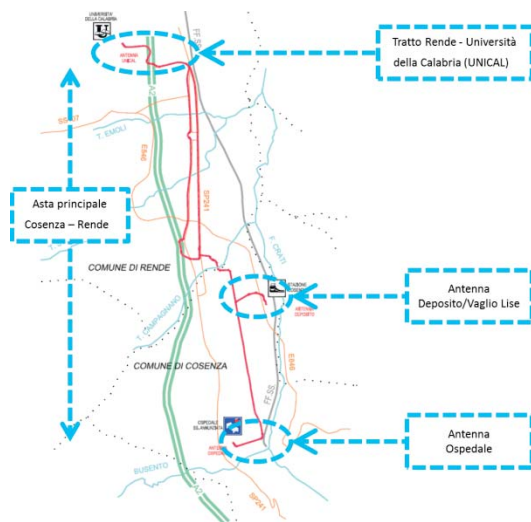

Besides the design of the tramway line, the project has required the reorganization of the whole road section interested by the tramway especially as far as the existing/new intersections and transversal road network are concerned. The design of the tramway line had to take into account specific geometrical conditions given by the tramway vehicle especially for sections without electrification where the system has to count solely on the battery power system.

The works include:

- electric power and traction systems,
- signalling/safety systems,
- telecommunication systems.

The project also includes a workshop and a depot for the tramway vehicles, the design of stops and of the terminal stations, the power electrical supply system, the signalling and safety systems, the electrical stations for the traction system.

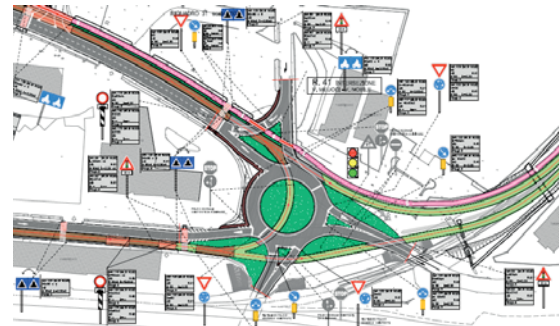

Special care has been paid for the design of the 35 stops from both the architectural and structural point of view. The study was concentrated on the architectural concept and a subsequent step of choosing the materials and the right proportion of the structural elements.

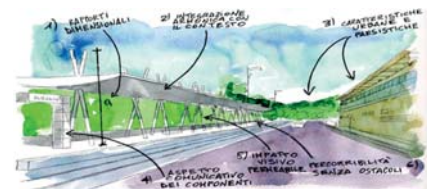

The detailed design has also incorporated bicycle path and an urban park for improving the inclusion of the new system into the urban environment.



WORKS FOR THE UPGRADING OF THE ADRIA-MESTRE RAILWAY LINE

Location:	Adria and Mestre, Italy
Client:	SISTEMI TERRITORIALI S.p.A. -Veneto Region
Services:	Preliminary and Final Design
Period:	03/2003 - 11/2003
Construction cost:	Euro 56,000,000

Project Description:

The project concerns upgrading works, the suppression of level crossings and the elimination of critical points along the alignment of the regional railway Adria-Mestre (northern section, Piove di Sacco – Mestre Km 0+000 - 15+497 and southern section, Piove di Sacco – Adria Km 0+000 - 23+144), in the Veneto Region. The contract included works for the static upgrading of the railway bridges across the Adige and Brenta rivers, as well as the works for extending the parking areas at some of the stations along the line.

In particular the designed works envisaged:

- 1) The elimination of level crossings at critical or major road crossings, replacing them with railway overpasses, road and cyclist/pedestrian underpasses, and new and/or improved road connections to one or more level crossings and the related road network;
- 2) The replacement of the steel decks of the railway bridges crossing the Adige and Brenta rivers, and the consolidation of the existing foundation structures;
- 3) The restructuring of some station buildings along the line and the widening of the platforms and installation of platform roofing;
- 4) The creation of new parking areas at some of the stops along the line;
- 5) The modernization of some sections of the track equipment.
- 6) Update/upgrade automatic control system and signaling.

Given the presence of the permanent surface water table, all the underpasses located below the natural ground level have water collecting tanks along the ramps (to depths of 1-1.5 m below ground level) and pumping stations to remove the rainwater.

The main structures foreseen included the following:

Underrail structures thrust into place

The underpasses to be built under the railway line in operation were designed using the technique precast structures "thrust" into place. These have a service or cyclist/pedestrian footpath along at least one side and a New Jersey barrier on the opposite side.

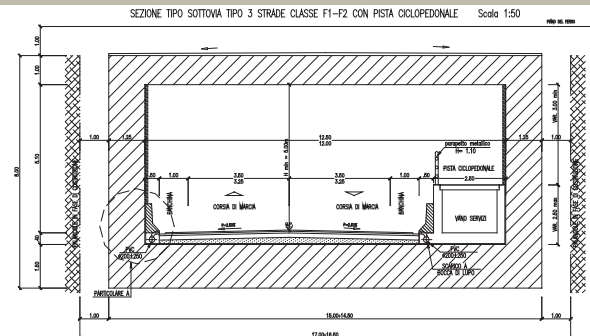

Railway bridges across the Adige and Brenta rivers

The two steel bridges for crossing the Adige and Brenta rivers, will be in the same position, and will be improved by replacement of the steel decks and partial modification or reinforcement of the foundation structures in reinforced concrete.

The new decks are of the same type as the previous ones, that is to say with the track fastened directly to the lower level so as to limit the height above the deck intrados and thereby maintain the same railway gradient. The girders are reticular in steel in parallel rows with a triangular "closed" type grid, i.e. braced both above and below. The bridge over the Adige has 3 simply supported spans with a central span of 40.00 and two lateral spans of 32.00 m. The bridge over the Brenta also has 3 simply supported spans with a central span of 43.60 m and two lateral spans of 337.20 m.

With regards the foundations, the project envisaged the reinforcement of the existing piers with a concrete jacket for the lower section which rests on micropiles pile around the base of the piers.

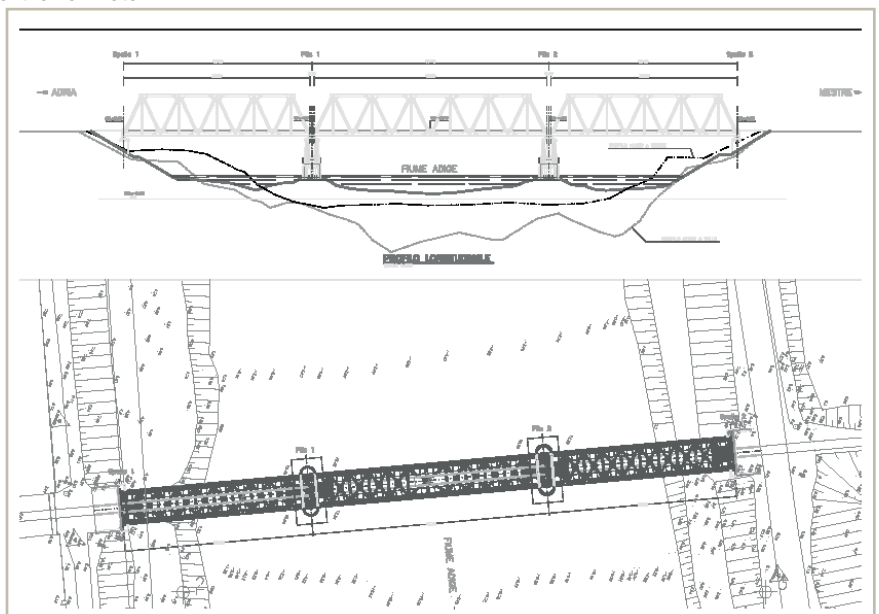

HIGH SPEED RAILWAY LINE MILAN-NAPLES. MILAN-BOLOGNA SECTION: CIVIL WORKS FOR A SECTION OF ABOUT 18 KM BETWEEN KP 45 AND KP 63

Location:	Milan-Bologna, Italy
Client:	Grandi Lavori Fincosit S.p.A. (member of the state concessionaire Cepav Uno Consortium)
Services:	Detailed Design
Period:	01/1997 – 12/1999
Construction cost:	Euro 108,000,000

Project Description:

The project referred to some structures on the section of the new high speed line of GLF competence as well as on the Piacenza East branch line. The works designed included:

- **1 railway viaduct with a pre-stressed deck, over 5 km long;**
- **1 8-span railway viaduct** with a multiple-beam deck in a mixed steel and concrete structure and piers in the river bed and stream;
- **2 single span railway viaducts** with a deck in a mixed steel and concrete structure;
- 1 artificial tunnel passing under the A1 Motorway and adjacent box culverts;
- 4 rectangular underpasses of various cross-sections and lengths, to guarantee the continuity of the roads interfering with the railway alignment. The largest and longest underpass includes a pre-cast section to be pushed into place under the A1 Motorway.



The services provided included, besides the **final design of all the permanent structures**, the **final design of the temporary works** necessary for the realization of the permanent ones. This part of the activity was also extended to the 9 railway overbridges foreseen in the section of line for which GLF is responsible.

JORDAN-IRAQI BORDER RAILWAY LINK. FIRST STAGE: AL ZARQA-TRAIBIL LINE

Location:	Jordan
Client:	Jordanian Ministry of Transport
Services:	Feasibility Study, Preliminary Design and Environmental Impact Assessment Study
Period:	07/1995 – 05/1996
Construction cost:	Euro 371,849,000

Project Description:

The existing railway was built at the end of 18th century, around the Etna volcano and climbing mountain slopes up to about 1,000 m above sea level, whereas the clockwise train departure in the context of the general development of the railway network in order to improve connections with the neighbouring countries of Syria, Iraq and Saudi Arabia, the Jordanian Ministry of Transport entrusted TECHNITAL S.p.A. in Association with ITALFERR - SIS.T.A.V. with the execution of the technical and economic feasibility study of the rail connection between Jordan and Iraq, the Al Zarqa - Traibil line.

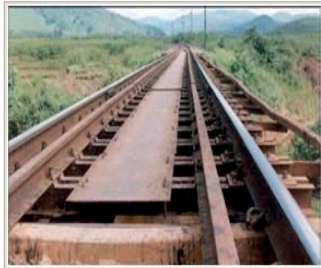

The project includes the definition of the track equipment and rolling stock, the design of 1,500 m of bridges and viaducts for the approaches to Al Zarqa, control and signalling installations, and the maintenance plants.

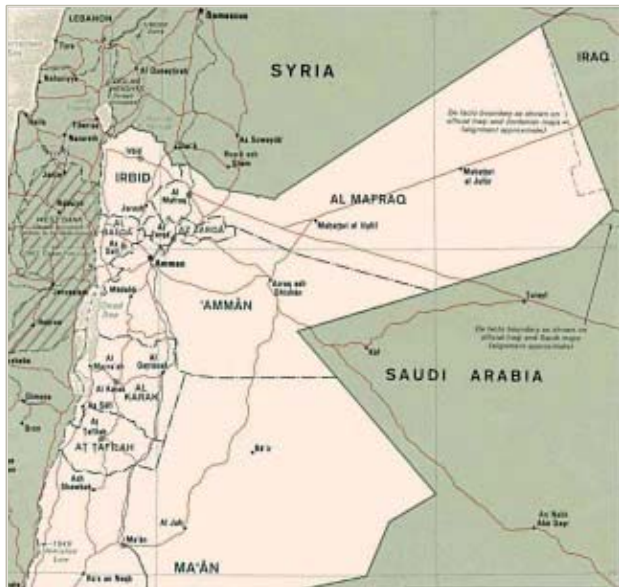

The new rail link of 300 km from Al Zarqa (north of Amman) to Traibil in Iraq is designed for diesel traction although predisposed for future electrification and has a design speed is 160 km/h for passenger trains and 120 km/h for freight trains.

RENEWAL OF THE EXISTING LINE DAMMAM-HOFUF-HARAD-AL KHARJ- RIYADH (560 KM) AND NEW DIRECT LINE DAMMAM-HOFUF-RIYADH (449 KM)

Location:	Saudi Arabia
Client:	Saudi Government Railways Organization (S.G.R.O.)
Services:	DEVELOPMENT OF THE SAUDI RAILWAY NETWORK: Feasibility Study, Concept, Preliminary and Detailed Designs, Tender Documents, Construction Supervision, Technical Assistance geotechnical studies and investigations
Period:	01/1978 – 12/1992
Construction cost:	Euro 516,500,000

Project Description:

In 1976 the only existing railway in the Dammam-Riyadh corridor was the single track *line of about 560 km connecting Dammam to Riyadh passing through the towns of Dhahran, Abqaiq, Hofuf, Harad and Al-Kharj.*

The S.R.O., aiming to develop the railways sector, entrusted Technital to carry out the Detailed Design and the works supervision relating to the *upgrading* of this line, which involved the complete redesign of the horizontal layout of the alignment with the introduction of geometric elements suitable to modern operative standards.

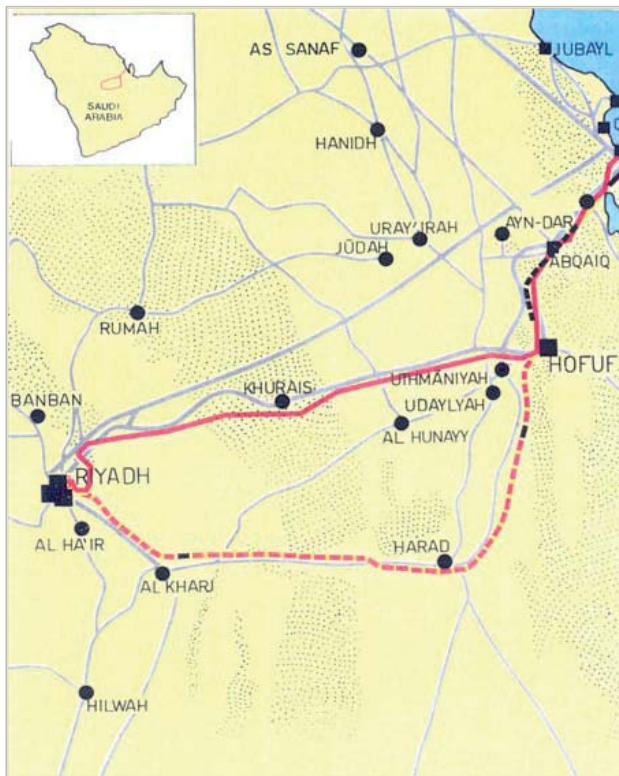

Successively Technital was entrusted with the feasibility study, preliminary and final designs, and works supervision of a new *high speed railway line between the capital, Riyadh and Dammam*, the main Saudi port on the Persian Gulf. The first part of this line, up to Hofuf, represents the doubling of the existing one.

The project also includes the ancillary facilities, above all the *three main railway stations* of Dammam, Hofuf, Riyadh and the *maintenance installations*, including a Major Maintenance Workshop in Riyadh for the maintenance of the Diesel-electric locomotives, a Running Repair workshop for rolling stock in Riyadh, and a Running Repair workshop for passenger cars in Dammam.

Renewal of the existing railway line Dammam - Hofuf - Harad - Al Kharj - Riyadh

The corridor which extends approximately 450 km. between Riyadh, the capital of Saudi Arabia, and Dammam, the main Saudi port on the Persian Gulf, is part of the corridor which extends toward the West to the port of Jeddah on the Red Sea. This corridor interests the most developed and most densely populated areas of the entire Saudi Arabian Kingdom.

In fact, in 1976, the year in which the S.R.O. began to sense the need to develop the Kingdom's railway network, the Dammam-Jeddah corridor could already count more than 3 million inhabitants, more than 43% of the nation's population.

The existing single-track railway in the Dammam-Riyadh corridor had been built in the distant 1930's and was principally the result of the necessity to transport machinery and equipment via railway to the Port of Dammam which was then destined to the water wells of Al Kharj, one of the nation's most important water reserves.

The decision to build such a long route was the logical consequence of the need to serve the important city of Harad and to cross the dune desert of Dhana in its most narrow spot. In fact, the desert was the most difficult environmental obstacle to construction and operation.



The Dammam-Al Kharj-Riyadh railway line had standard rail gauge and was run via a VHF radio

system directly from the Central Office in Dammam through a direct radio contact between the controller and the driver. There were two passenger trains daily with a rather limited composition, one departing in the morning from Dammam and the other from Riyadh in the afternoon. There was also one freight train daily from Dammam to Riyadh with a variable composition of 40 to 60 wagons.

The operational and structural conditions of the railway certainly did not constitute an adequate base for the redevelopment of a new and more efficient railway service capable of handling a growing passenger and freight transport demand.

It was then that S.R.O. realized that it was necessary to begin contemplating the in-depth overhaul of the existing infrastructures and the simultaneous construction of new infrastructures. Consequently S.R.O. entrusted Technital with the task of developing the final design and supervising the works for the renewal of the existing railway line between Dammam and Riyadh.



The final design foresaw the complete redesign of the horizontal layout of the alignment with the introduction of geometric elements suitable to modern operative standards. A topographic investigation was first launched to define the layout of the terrain and the existing railway with the survey of the centreline every 50 m. in straight stretches and every 25 m. in curves.

Later, through a specific calculation program, the geometric elements between the axis points surveyed were defined by computer, thereby allowing the definition of the geometry of the entire alignment, even through the introduction of transition curves not existing in the old infrastructure. At the same time, the gradients were redefined and the permanent way was fully replaced.

New Direct Line Dammam-Riyadh

The need for an efficient transportation system in the Kingdom of Saudi Arabia was recognized at the beginning of the 1970's at which time the country's great economic growth gave way to a very large increase in transportation demand which constantly surpassed the supply, especially in the more important areas like the strip which extends approximately 450 km. between the Capital, Riyadh and Dammam, the main Saudi Arabian port on the Persian Gulf.

This led the Saudi Arabian Government to concentrate the nation's financial resources on the development of transportation systems which required short-term realization times, like the highway and airline systems, penalizing in this manner the development of the railway network.

It was only toward the mid 1970's that following a change in interest for the railway sector, the S.R.O. began to understand the need to give new energy to the sector through the process of reorganizing the existing infrastructural assets and through the construction of new railway lines.

Therefore, following the contract to carry out the executive project and supervise the works to overhaul the existing Dammam-Hofuf-Harad-Al Kharj-Riyadh railway, the S.R.O. also entrusted Technital with the task of conducting the feasibility study, the preliminary and final designs and supervision of the works for the new direct railway line between Dammam and Riyadh which would shorten travel time considerably with respect to the existing line through Harad and Al Kharj.

An in-depth and complete analysis of the transportation within the Dammam-Riyadh corridor was done, also by evaluating the convenience of starting a direct high speed (250 km/h) connection for passenger service. The study began with the preparation of a 1:250.000 scale map and identification of five possible alternatives.

Successively, based on the traffic data collected, and on-site inspections done along the different alternative routes, two possible hypotheses for intervention were chosen for comparison in the economic analysis:

- connection between Dammam and Riyadh through Hofuf (alternative no. 1)
- a direct connection between Dammam and Riyadh (alternative no. 2)

Based on the data collected, a graph of the transportation system associated with each alternative was developed. Through the same mathematical model, the demand for transportation within the system was then assigned, also by simulating the volume of freight and passenger traffic in the year 2000 based on various hypotheses of growth in transport demand. Each alternative was subsequently developed on the preliminary design level by defining the technical and operating standards of the new railway line and the related investment, operating, and maintenance costs. Cost breakdowns were then elaborated and, through comparison with the opportune system of general reference, the benefits associated with each alternative and the relative economic indexes were defined.

Upon termination of the economic analysis and in agreement with the S.R.O., alternative no. 1 was chosen, envisaging a single-track line Dammam-Hofuf-Riyadh which, flanking the existing railway in the stretch between Dammam and Hofuf, in fact doubles it.

The final design which followed the feasibility study was divided into the following work phases:

- aerophotogrametric survey of the terrain followed by a topographic survey for the identification, staking and benchmarking of the photograms and subsequent mapping;

- geophysical and geotechnical surveys on the nature and bearing capacity of the terrain and the availability of borrow pits for construction materials. Particular attention was paid to defining the influence that the presence of quicksand and vast deposits of sulphate sand (sabkha) could have on the infrastructure;
- hydrological and hydraulic study;
- preparation of the final design which included the definition of the horizontal and vertical lay-out of the structure, the permanent way and all of the other elements comprising the railway infrastructure;
- preparation of the tender documents for the construction of the railway line.

The final alignment of the railway line originated from the necessity to guarantee the most direct connection possible between Dammam and Riyadh while taking into consideration the various constraints which could affect it. Therefore, for the section between Dammam and Hofuf, the lay-out followed the existing railway line, whereas in the section between Hofuf and Riyadh the lay-out was conditioned by:

The railroad was designed for a diesel-electric traction system with standard 1,435 mm. rail gauge, a project velocity of 150 km/h, and a maximum axial weight of 22 tons (locomotive) and 25 tons (wagons). The horizontal curve radius was set at a standard measure (2500 and 5000 m.), when possible. The minimum radius in straight stretches is 2000 m. and 1750 m. in the sections between Hofuf and Riyadh and Dammam and Hofuf respectively. The maximum gradient is 10 per 1,000 (non-compensated). The total length of the line is 449 km.



The location and number of stations along the line were defined to serve the major inhabited areas, as well as the areas of special interest, and to guarantee an adequate level of railway capacity in relationship to the amount of traffic expected. Four intermediate stations were planned between Dammam and Hofuf and seven between Hofuf and Riyadh.

The permanent way was built with U/C 60 rails which were continuously welded between stations. The sleepers are of the monobloc p.r.c. type which were produced locally in two new plants built in Riyadh and Hofuf, for which the installation and production tests were followed by Technital on behalf of the S.R.O. The coupling devices are the indirect elastic type (Pandrol and Vossloh). The switches are U/C 60 type with a 1/12 tangent (on the railway line), 1/9 (at stations), and 1/7.5 (in freight yards).

The track formation has an overall width of 7.69 m on embankments and 17.6 m. in trenches, in that two 5 m. lateral paths were planned to enable transit of maintenance vehicles and to protect the track from slopes. A layer of a granular mixture of subballast was also foreseen in the composition of the superstructure.

Lastly, a special effort was required for the protection of the railway in crossing the areas of quicksand and sabkha.



In the first case, sand slopes with a slight gradient (1:4) were utilized and were stabilized with a series of superimposed layers of compact granular mix (protective windrows). In cuttings, ample, adequately shaped sections were planned in order to halt the advance of the dunes. In the second case, protection of the sabkha was obtained through the use of non-woven fabric and preloading of the embankments. The aggression of the sulphate of the sabkha on the concrete elements cements was controlled through the use of sulphate-resistant cements, of waterproof cements produced with a low water/cement ratio, and of super fluidizers to keep the mix in good working order, even in a hot climate.

The hydrological survey led to dividing the territory crossed by the railway into three areas, each one characterized by its own rainfall pattern. Therefore, the three distinct equations of climatic probability were elaborated first, even if the equation relative to the zone of the highest precipitation was later considered opportune for all three zones. Based on the rainfall data collected from the Saudi Arabian Ministry for Agriculture, as well as specific site surveys, the maximum flow rates were calculated, on the basis of which the hydraulic works were then dimensioned.

The structures foreseen in the project were located in the Hofuf-Riyadh section and include a total of six bridges and two viaducts for an overall length of 2,150 m. Considering the rather difficult environmental conditions and the difficulty in transporting heavy loads along the route, utilization of structures in prestressed, precast concrete were used at the base of the works and then launched. All of the construction works were planned in view of the possibility of doubling the Hofuf-Riyadh line with the purpose of reducing future interruptions to railway operations to a minimum.

INTEGRATED TRANSPORTATION SYSTEM FOR THE DEVELOPMENT OF THE KAGERA RIVER BASIN

Location:	BURUNDI - RWANDA - TANZANIA - UGANDA
Client:	Kagera Basin Organization - U.N.D.P. - Financing by the Italian and Austrian Governments.
Services:	Feasibility Study, Concept and Preliminary Designs
Period:	05/1982 – 12/1984
Cost of Services:	Euro 1,817,900

Project Description:

The Kagera River Basin region lies 1000 km from the Indian Ocean and 1900 km from the Atlantic Ocean.

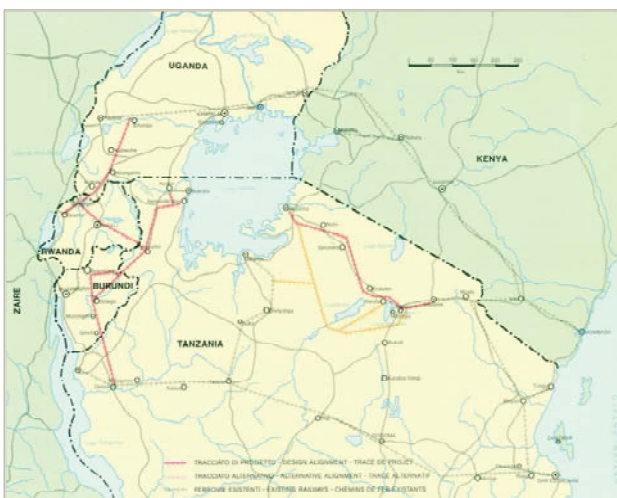

The only link to the sea at the present time is provided by a road network, in precarious condition, which crosses Uganda and Tanzania to connect with the ports of Mombasa and Dar Es Salaam in the east. This situation constitutes a serious obstacle to the socio-economic development of the region. Studies already carried out by the UNDP have indicated that a rail network is the best solution to this problem.



The project therefore had the following aims:

- draw up a detailed and up-to-date picture of the socio-economic situation
- quantify and evaluate the conditions of the existing transport structures (roads, railways, lake and ocean ports, etc.)
- identify possible new railway links to the existing lines

- evaluate which system can guarantee the most immediate economic return whilst ensuring adequate strategic safety and operational flexibility
- estimate the cost of realisation and draw up possible intervention scenarios.

To this end, through a detailed study of the present socio-economic situation, the current rail transport demand and the demand foreseen for 2000 and 2020 were identified. Accurate evaluations were then made of the efficiency and maintenance of the current transport systems (railways, roads, lake and sea ports) in the four countries occupied by the Kagera Basin, and of present running costs.



The railways needed to link the main towns in the region with the existing lines, and possible alternative integrated systems, were then identified:

- North Corridor which connects through to the port of Mombasa in Kenya across Lake Victoria, using the existing line Kaese (Uganda)-Nairobi-Mombasa;
- Central Corridor which connects through to the port of Tanga in Tanzania across Lake Victoria, using the existing line Arusha (Tanzania)-Tanga;
- South Corridor which connects through to the port of Dar Es Salaam in Tanzania, using the existing line Kigoma (Tanzania)-Dar Es Salaam.



It was thus possible to evaluate the investment costs and operating costs of the different networks and, through a socio-economic Feasibility Study, identify the related economic indicators for each system. These evaluations showed that the Internal Rate of Return (IRR) of the various systems varies from a minimum of 6.2% for the North Corridor to a maximum of 10.3% for the Central Corridor. Finally, for this latter network, which was the solution recommended for implementation, the intervention priorities and investment programme were defined.

Of all the new railway lines identified a Preliminary Design was drawn up. Furthermore, a Preliminary design was done for all the upgrading and restructuring of the existing railway lines as well as of the ports on Lake Victoria and on the Indian Ocean considered necessary to ensure the required operating capacity.

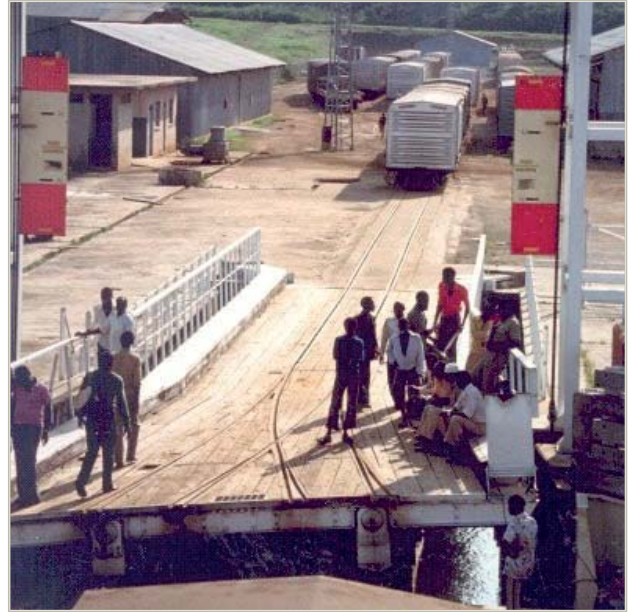

Urban Transport

DETAILED DESIGN OF THE LINE 4 (SECTION CAMPI BISENZIO – SESTO FIORENTINO) OF THE TRAMWAY IN FLORENCE

Location:	Italy, Florence
Client:	Municipality of Florence
Services:	Detailed Design
Period:	11/2023 – ongoing
Construction cost:	Euro 178,069,427

Project Description:

The design of the extensions of the tramway lines in the municipalities of Florence, Campi Bisenzio and Sesto Fiorentino, is part of the broader planning framework of the tramway system of the Metropolitan City of Florence, conceived with the aim of creating an organic mobility system, innervated over the entire city of Florence and main neighboring urban centers. In particular, Line 4.2 constitutes the connection from Le Piagge station to the town of San Donnino and from there to the center of Campi Bisenzio and represents the extension of Line 4.1 Leopolda Station - Le Piagge: together they constitute tramway line 4. In its development, Line 4.2 insists on the municipal territories of Florence, Campi Bisenzio, and its length is about 5.4 km. The line includes 11 stops, 4 park-and-ride parking lots, an area for streetcar storage and maintenance, and 4 main works of art to cross the hydrographic network, the largest of which has a length of almost 140 m.

The project envisages the construction of several buildings within the "Depot Area (approx. 32,900 sqm), which are mainly required for office accommodation, material storage and vehicle maintenance.

A vehicle washing area, the maintenance workshop and annexed offices, the tram vehicle depot, the plant and related electrical substation (SSE) and the plant maintenance workshop are planned. In particular, the Depot building is dimensioned to allow the storage of 18 vehicles with internal tracks of a maximum length of 35 m. All structures are planned with prefabricated elements in order to minimise construction time.

Along the route, 11 stops are planned, in addition to the final head station in the municipality of Campi Bisenzio. The stops are of two types: with a central pavement or with pavements, all raised above street level and placed at the same height as the floor of the rolling stock. At each stop there is a metal canopy with transparent elements, as well as technological and information equipment such as a ticket issuing machine, information panels on the line, the route and the waiting time of the trains.

The plant equipment includes the usual systems serving the tram network, such as the traction line, electrical substation system, signalling system, traffic light location and priority, traffic light systems, telecommunications and remote-control systems. Civil installations (lighting) and depot systems complete the equipment.

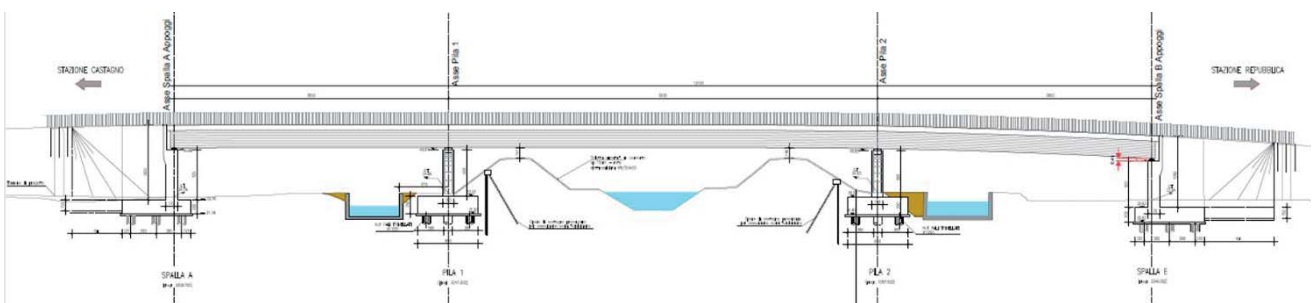

DETAILED DESIGN OF THE LINE 3.2.1 (SECTION "LIBERTÀ" - BAGNO A RIPOLI) OF THE TRAMWAY IN FLORENCE

Location:	Italy, Florence
Client:	Municipality of Florence
Services:	Detailed Design
Period:	11/2023 – ongoing
Construction cost:	Euro 201,724,000

Project Description:

The design of the extensions of the tramway lines in the municipalities of Florence, and Bagno a Ripoli, is part of the broader planning framework of the tramway system of the Metropolitan City of Florence, conceived with the aim of creating an organic mobility system, innervated over the entire city of Florence and main neighboring urban centers. In particular, Line 3.2.1 constitutes the connection from Don Minzoni Avenue/Libertà square to the town of Bagno a Ripoli. In its development, Line 3.2.1 insists on the municipal territories of Florence and Bagno a Ripoli, and its length is about 7.2 km. The line includes 17 stops, 3 park-and-ride parking lots, an area for streetcar storage and maintenance, and 2 main works of art to cross the Arno river, the largest of which has a length of almost 180 m.



In addition to the civil works (carried out by our client CMB), project also includes the construction of the electric traction system, signaling system, and parking access control system.



Fermata 9 Verrazzano: Stato Attuale

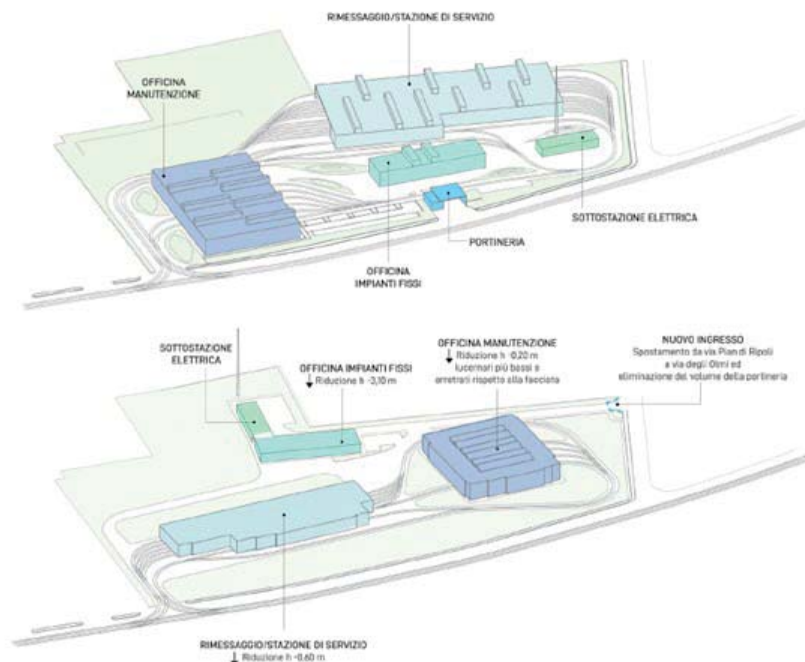

TRAMWAY SYSTEM OF PALERMO

Location:	Palermo, Italy
Client:	Municipality Palermo
Services:	Feasibility Study of 7 lines, detailed design of the first lot of 3 lines
Period:	07/2018 – on going
Construction cost:	Euro 516,507,300

Project Description:

The expansion of the tram system of Palermo aims at the ambitious goal of providing the city with a secure, modern, punctual, comfortable, silent and zero emission transport service. The planned tram network is fully integrated into the Local Public Transport of the city of Palermo, based both on fast metropolitan mobility systems and urban and extra-urban road transport systems. The purpose is to create an intermodal transport system that connects and makes accessible the main areas of the city, the university and hospitals, the suburbs and the seaside villages.

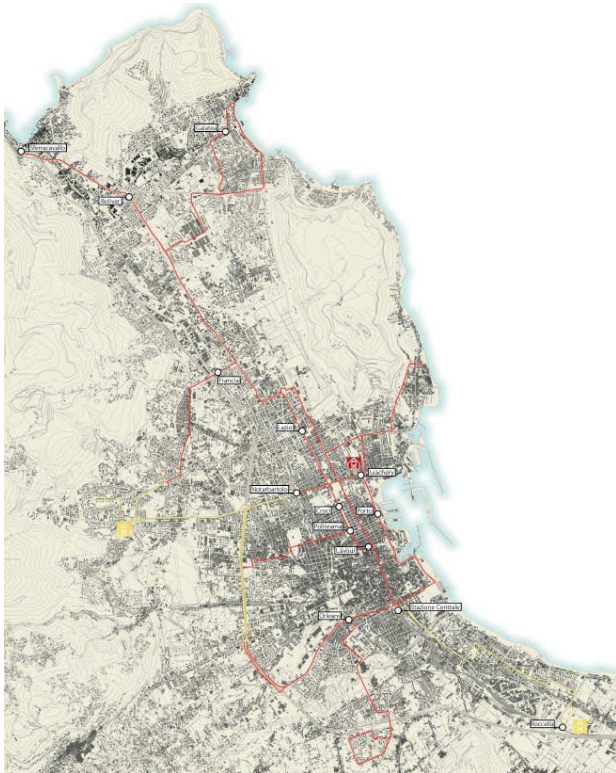

The technical and economic feasibility project relates to 7 lines sections for a total of approximately 67 km of network; the project also envisages the construction of a new warehouse, the re-organisation of some urban interchanges and a network of 14 multi-storey car parks.

The standard sections are single and double-track, both protected and traffic mixed lanes.

The whole new tram network is entirely catenary free, with gauge identical to that of existing lines and equipped with hybrid vehicles.

The catenary free system provides for the adoption of a cutting edge technological solution among those present on the international scene, represented by cars equipped with ultra-light and high capacity batteries and super-capacitors, with short charging periods and considerable autonomy. This technology is the only one that allows the transformation of existing cars into hybrids, allowing the service also on new routes with obvious economic - managerial advantages. The proposed refill system has been selected to offer the best possible combination of production and management costs, functional efficiency and, above all, impact reduction. This system provides, in addition to recharging deposits when the rolling stock is not in service, the application of

the opportunity charging, which allows recharging during braking and at some special stops, as well as a specific power management system widely tested.

The main works are:

- The viaduct on the Orio, which with an expected development of about 180 m, and a cross-section of almost 34 m, crosses the gorge of the river Oreto supported by an tied-arch structure. The bridge is for a double-track tramway, 4 road lanes and 2 cycle / pedestrian tracks.



- The Leonardo da Vinci Viaduct with two lanes and 4 spans of maximum 46 m
- The Calatafimi Viaduct of 6 spans of about 20 m.
- The cut-and-cover tunnels for the intersection with via Basile which consist of the construction of two single-lane artificial tunnels that will converge in a single double-track tunnel under the main avenue (Viale Regione Sicilia) and two road underpasses.
- Pedestrian overpasses via Regione Sicilia, realized with two double-span pedestrian metal walkways of about 30 m and 45 m respectively.
- Giachery Depot dedicated to the overnight stop of about 40 cars, to the cleaning and daily maintenance of the cars in service on 5 lines.

Besides the civil works, the project covers all the technological aspects of the line and of the station such telecom, signalling and command/control.

Finally, the project envisaged the adoption of innovative plant components and rolling stock, such as:

- the use of newly designed two-seater vehicles, with a totally lowered floor to facilitate the carriage of people with limited mobility, with a double feeding system equipped with energy recovery systems in braking / descent;

- reduction of maintenance costs of the system and of the traction and power plants;
- n 5 charging stops;
- n 2 new terminals serving the D and G sections;
- traffic light enslavement at intersections;
- centralization in one place of the system of control and supervision of the operation of the whole system;

- adoption of line track-works that realize the optimization between costs and benefits, obtained in terms of noise and transmitted vibrations;
- high efficiency and low consumption lighting systems;
- energy production plants from renewable sources.

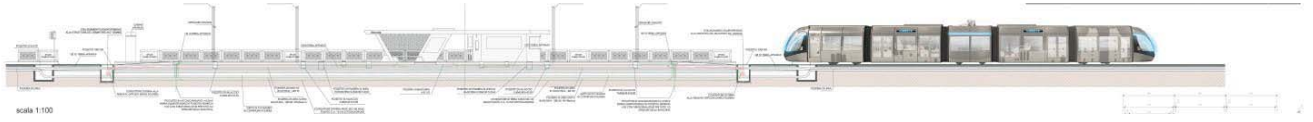

DETAILED DESIGN OF THE NEW URBAN RAIL LINK BETWEEN THE STATIONS OF GERMANETO AND SALA AND OF THE UPGRADING OF THE EXISTING LINK BETWEEN THE STATIONS OF SALA AND LIDO IN CATANZARO

Location:	Catanzaro, Italy
Client:	Metrofc S.ca r.l. (Stazione Appaltante Regione Calabria)
Services:	Detailed design
Period:	11/2015 – Ongoing
Construction cost:	Euro 88,038,312

Project Description:

This project refers to the doubling of the light rail line between Sala and Lido stations, and to the construction of new single-track urban light rail between Germaneto and Sala with all the mentioned stations falling into the municipality of Catanzaro.

The Sala – Lido link is 8,3 km long and it is narrow gauge with 8 stops including the 2 terminal ones.



Rendering of Lido Station

The Germaneto – Sala is 5.0 km long and not electrified narrow gauge with 3 stops with the last one on the same platform in Sala as the Sala – Lido and therefore allowing an easy transshipment for the passengers.



Rendering of Sala Station.

The works along the 2 tramway lines are relevant and includes several section in trench and several cut-and-cover sections. Important viaducts, overpass and underpass have been also considered along the line for reducing the interference with the car and pedestrian traffic.



Rendering of Fiumarella viaduct.

The permanent way for the Sala – Lido is made of UNI50 and precast/prestressed concrete sleepers while for the Germaneto – Sala the existing permanent way will be reused (UNI36 and wood sleepers).

The stations and stops have been also studied from the architectural point of view in order to limit the visual impact in respect to the landscape.

At the same time the project has envisaged several environmental friendly measures (green barriers, noise barrier, bicycle lanes, and urban park area in the former station area).

The design covers

- automatic control system
- electric power and traction systems,
- signalling/safety systems,
- telecommunication systems,
- lighting
- “smart city” devices, devices at the stops, electromechanical plants, etc.



Rendering of Campus Stop

DESIGN AND BUILD FOR THE CONSTRUCTION OF THE FIRST TRAMWAY LINE IN BOLOGNA (RED LINE)

Location:	Italy, Bologna
Client:	Municipality of Bologna
Services:	Detailed Design
Period:	06/2022 – 04/2023
Construction cost:	Euro 331,577,463

Project Description:

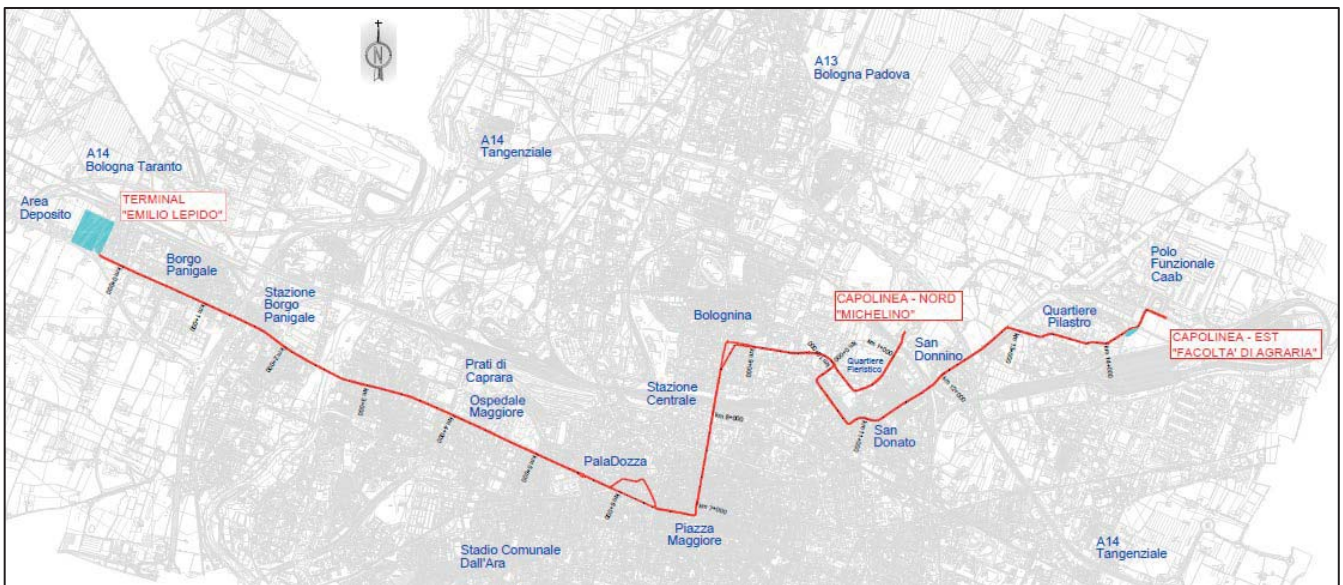

The project relates to the First Bologna Tramway Line (Red Line), which extends from the western outskirts of the city, in the Borgo Panigale district, crosses the city's historic center, and ends at the two terminals located respectively in the Fiera area, in the northeast quadrant of the city (Terminal Michelino) and at the Faculty of Agriculture, at the eastern end of the city, near the Pilastro district.

Its total development is approx. 15 km for the axis that connects the Borgo Panigale Terminal with the Faculty of Agriculture Terminal, to which is added the 1.3 km of the northern branch that connects the bifurcation at the entrance of the Region's Palaces on Via Aldo Moro and the northern Terminal "Michelino", where a second interchange between private vehicles, suburban public transport lines and the new tram service is located.

The design of the Tramway Line is partly double and single track, with a standard track gauge 1435 mm. The tramway line crosses the entire city from west to east, connecting the main attractive areas of the city. The historic center of Bologna has many significant areas of high historical, architectural and landscape value where the presence of the power supply area line, piling and supporting ties would constitute a serious source of "visual pollution."

The alignment insists, almost entirely, along the existing road axes, keeping almost unchanged the elevations of the top of rails with respect to the road level.

In addition, for about 25 % of the line, the design includes a power supply solution for next-generation electric traction, without overhead catenary, where the tramway will move autonomously with the power supply system provided on board the rolling stock.

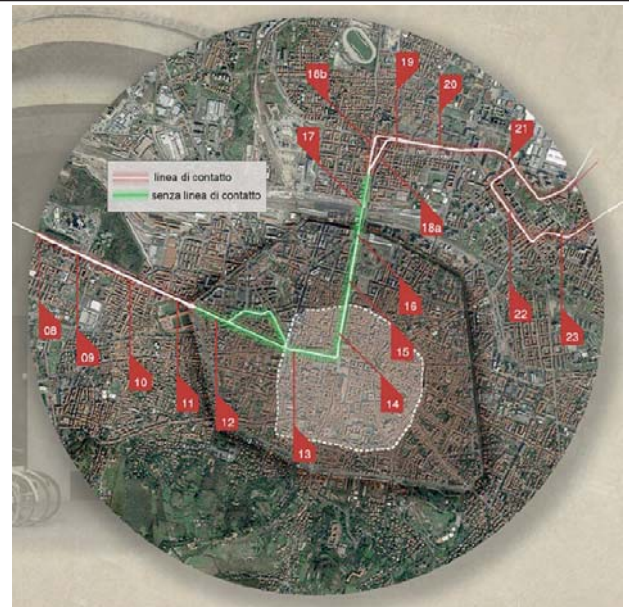

In fact, the project implements the most innovative and efficient technological solutions available on the market, while at the same time interpreting requirements arising from the overall sustainable ecological approach to transportation, the need for redevelopment of the urban spaces, and the need to connect all modes of transportation via multimodal interchange hubs within existing and planned interchanges.

For almost all its development, the streetcar proceeds along a reserved lane, with the aim of reducing interferences with remaining urban mobility, both public and private: this feature is achieved by raising the tramway line by a maximum of 7 cm with respect to the parallel road lanes, so that the line can still also be used in case of emergency.

The tramway cross section has a width of 6.00 m with an intertrack spacing of 3.00 m.

At least one road lane is always positioned in parallel to the new tramway section, with the exception of sections located in the city center (via Ugo Bassi, via Indipendenza).

Such parallel lane is always to be wide enough to ensure the passage of heavy vehicles.

Along the 15.5 km of track joining the two terminals are placed 34 intermediate stops, at an average interval of ca. 450/500 m.

The design offers, mainly, two types of central and lateral stops that are adapted to the urban line arrangements to integrate, as best as possible, with the urban context. The lateral stopping platform has a width of 2.5 m and a length of 37 m, to which are added the two head ramps having, each a development of 5 meters. A rubber profile is provided for the vehicle approach. Pavements are in granite slabs in the downtown stops with granite curbs, and in those outside the center they are in stoneware with concrete curbs.



The central stopping platform has a width of 3.5 m and a length of 37 m, to which are added the two head ramps having, each a development of 5 meters and an attachment face of 3.18 m; it has the double approach to allow the stopping of one car on each side at the same time. A rubber profile is planned for the vehicle approach.

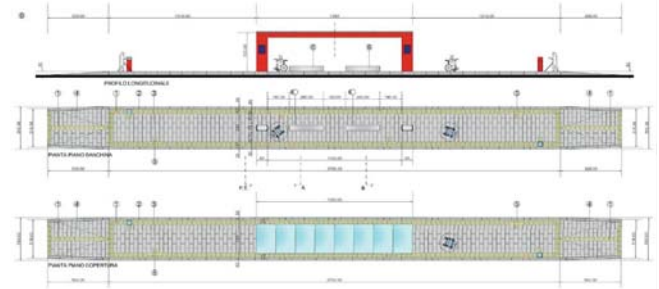

The project involves the construction of two depots at the ends of the line. The main one is in Borgo Panigale needed both for overnight shelter of vehicles and for routine and "heavy" maintenance. It is planned to construct a building that allows maintenance for 60 vehicles, and park for 40 vehicles of the length of 42 m.



The auxiliary depot Pilastro serves as additional storage of rolling stock and consists of two buildings one for storage use and one for service use (technical rooms, custody, toilets).

The line has been split into 6 macro-lots, which were identified based on the characteristics of the planned line.

The above-described lots are named by letters as below:

- Lot A - West terminus "Borgo Panigale"
- Lot B - Main tramway line section
- Lot C - Downtown tramway line section without L.d.C.
- Lot D - Via Matteotti / P.zza Unità tramway line section

- Lot E - North branch tramway line section ("Michelino" terminus)
- Lot F - East branch tramway line section (Terminus "Faculty of Agriculture")

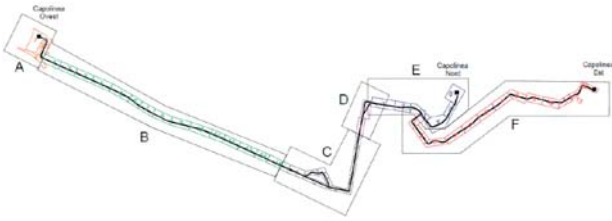

The geometry of the track has been identified and designed in compliance with the reference values provided by the UNI standards for tramways specifically at UNI 7156:2020 "Urban and suburban tramways - Minimum distances of fixed obstacles from rolling stock and intertrack," UNI 7836:2018 "Subways and tramways - Planometric course of tracks as well as UNI 8379:2000 "Constrained guided transport systems (rail, metro, light rail and tramway) - Terms and definitions."

The reinforcement system designed for the entire track, capable of significantly lowering the vibration component that is transmitted through the ground to surrounding buildings, is the so-called "embedded track" also known as ERS (Embedded Rail System), which involves the installation of insulated tracks on continuous support with homogeneous elasticity (concrete blocking slab), without mechanical fastening. The ERS system consists of the installation of 60R2 groove rails covered with rubber profiles, with the "top-down" method, that is, carried out from top to bottom. The rails supported by metal portals are placed and adjusted in height and gauge, and finally the reinforced concrete blocking slab is poured.

In addition to the rails covered with profiles made of a high-density granular elastomer, to reduce the vibrations transmitted from the "reinforcing slab - rails" system to the surrounding ground.

To collect water away from the rail throat, there are four holes with a diameter of 16 mm/each are drilled inside the throat that are put in communication with the drainage duct.

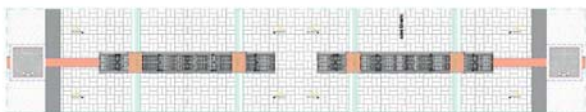

The proposed collection ducts are made of polymer concrete (high durability) and specially manufactured for tramway drainage.

The ducts have such a conformation and length that can adapt perfectly between the two tracks and at the same time they are equipped with a special shape profile to collect water that has gathered in the rail throat. Completing the drainage system of the tramway are cast-iron grates (driveways) equipped with special protection and locking device, which ensure easy maintenance.



Running parallel to the tramway are two ducts intended to contain the telecommunication - signaling - tripped circuit cables and to the low-voltage cables - feeder - traction ground - fiber optic - public lighting, control and distribution of electricity to the devices along the line and at the stops.

The duct is made of concrete with external dimensions of 70 cm x 40 cm (h) and consists of eight rigid PVC pipes with a diameter of 125 mm/each.

For the Medium Voltage (MV) power supply, in the central part of the tramway seat, a concrete cable duct is located, with external dimensions equal to 50 cm x 30 cm (h), and consists of two rigid PVC pipes of diameter equal to 160 mm.

For the laying of the pipes and their inspectability, the cable duct is provided with special branch manholes and branch breakers placed at spacing of about 30 m (at the TE poles).

The Electric Traction Power System involves the division of the Contact Line (where provided) into electrically separated sections by means of section isolators. Each zone will be fed bilaterally by two adjacent Traction SubStation (TSS). At each section isolator, a disconnecter of the motorized, normally open type will be able to reconfigure the power system in case of out-of-service and/or maintenance of each TSS, so that the adjacent TSSs can bear the entire traction load.

This is the most onerous condition from the electrical point of view, both in terms of the sizing of the transformer/rectifier unit of each TSS (it must be able to bear the load of an entire section normally fed bilaterally) and for the Contact Line (the voltage drop must be contained within the limits prescribed by the standards considering the total number of vehicles on the line). Even if the Depot TSS is out of service, the same may be fed from the nearest Line TSS by closing a motorized disconnecter at the entrance of the Depot.

The Red Line is based on two signaling subsystems (tramway and street), coordinated by an Operating Aid Subsystem located at the central control post of the Borgo Panigale depot. The Tramway Signaling Subsystem (or signaling tout court) deals with the protection of areas where conflict between multiple streetcars could occur.

The Traffic Signalling Subsystem, on the other hand, is regulated by the Highway Code through the related traffic light systems. The Operating Aid Subsystem combines the information from the two signalling subsystems and, together with the SCADA supervision system, allows operators at the central post to access the diagnostic, video surveillance, user information, and stop and substation communication services necessary for the proper operation of the tramway line, and to operate and maintain the line to achieve maximum efficiency.

All the above subsystems rely on the communication services provided by the fixed fiber-optic infrastructure to connect the ground devices and the LTE and WiFi radio infrastructure to connect with the rolling stock.

FAST TRAM PARCO NORD – SEREGNO IN MILAN

Location:	Milano, Italy
Client:	Ministry of Transport
Services:	Detailed Design
Period:	12/2013 – on going
Construction cost:	Euro 120,000,00.00

Project Description:

The Milan North Park - Seregno metrotranvia project is part of the "strategic program of works of pre-eminent national interest" and is part of the context of a strategic planning of regional and provincial scope, crossing n. 8 municipalities (Milan, Bresso, Cormano, Cusano Milanino, Paderno Dugnano, Nova Milanese, Desio and Seregno) and belonging to 2 Provinces (Milan and Monza Brianza). The line serves the historical route of the "Valassina" mainly along the former SP9 following the route of the old urban tram (current Milan - Desio and ceased Desio-Seregno-Carate), which leaves only in the last stretch, from Desio to the terminus of Seregno FS, to serve the Desio hospital and to realize the interchange with the Seregno railway station. The route has a length of about 14.3 km with a first double-track section from Parco Nord to Paderno Dugnano, Calderara (5.6 km) and the second part of the line, from Calderara to Seregno FS (8.7 km) is single track with double track only at the crossings.



The design criterion adopted is to create a non-paved tramway (single or double track) generally located in between the two carriageways intended for ordinary traffic and well established in the urban network (25 stops with a maximum distance of 540 m).

Besides the civil works, the project covers:

- automatic control system
- electric power and traction systems,
- signalling/safety systems,
- telecommunication systems,
- device for advice to the passengers.



The high-level performance of this transport system in terms of commercial speed, is primarily guaranteed by the adoption of a dedicated route along almost the entire line such as to minimize the interference with ordinary traffic and from 10 line doublings in the second part of the single track line in correspondence with the stops.

Various construction methodologies have been taken into consideration as far as the tramway permanent way is concerned. The aim was to guarantee the best performance in relation to costs, speed of execution, reduced occupation and noise of the construction site. The different constructive methodologies considered range from ballast, to precast slabs, to precast solutions for intersections, and systems for the automatic laying of concrete slabs.

Along the line the following main works are planned:

- a cycle-pedestrian underpass under the A4 in the municipality of Bresso;
- n. 8 electrical substations, of which 4 underground (19 x 16 m) and n. 4 above ground (17 x 12 m) each with n. 2 conversion groups c.a./c.c. of reversible type
- HESOPTM (Harmonic Energy Saving Optimizer) able to switch back to the medium voltage network the energy generated by the braking of vehicles and also regulate the supply voltage in order to keep it constant;
- tram depot, located on the border between the Municipalities of Desio and Seregno, which replaces the existing deposit north of the center of Desio. The new workshop depot, located on the border between the Municipalities of Desio and Seregno, is sized to house two-way trams, as well as a large portion of those destined for the Milano Castello-Calderara service. In particular, the deposit is able to accommodate 34 large-capacity trams, with a length of about 35 meters. For the maintenance of the rolling stock of the line, the depot includes a workshop equipped with inspection pits, gangways for the maintenance of the equipment on the roof of the cars, system for lifting the rolling stock, jib crane, bridge crane, etc.

In addition, the project involves the revamping of three disused tracks in Cusano Milanino and Desio for a total length of about 5 km and the construction of an interchange car park in Paderno

Dugnano of about 6000 square meters with about 180 parking lots.

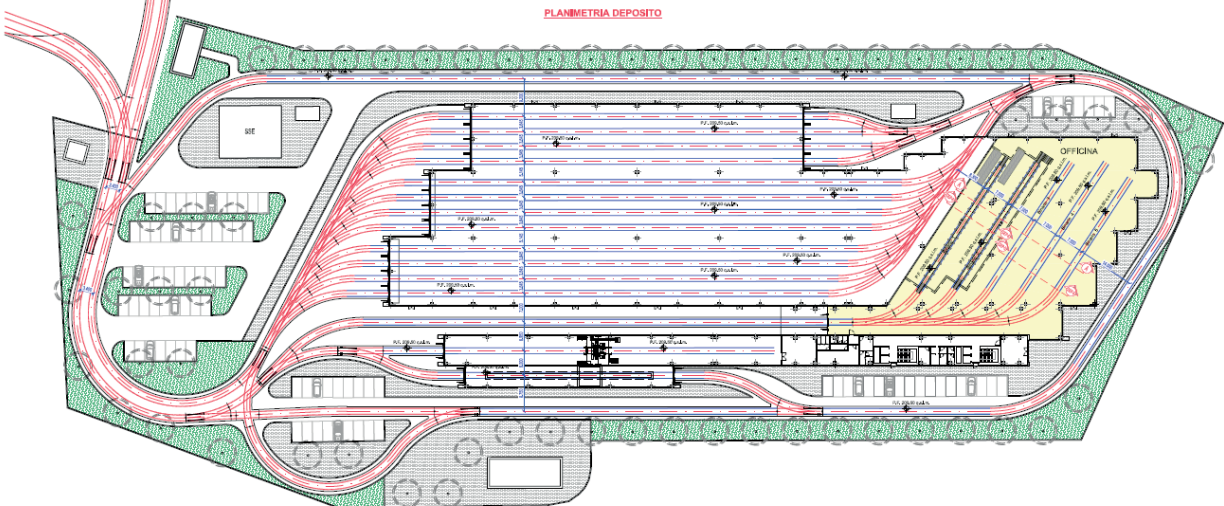

DETAILED DESIGN OF THE TRAMWAY RENDE - THE UNIVERSITY OF CALABRIA IN COSENZA

Location:	Cosenza - Italy
Client:	Cooperativa Muratori & Cementisti C.M.C. - Ravenna
Services:	Detailed Design
Period:	05/2016 – 05/2020
Construction cost:	Euro 96,031,133

Project Description:

The detailed design of the tramway between Rende and the University of Calabria in Cosenza concerns mainly the construction of a tramway line on existing urban roads, with the exception of the section connecting the University of Calabria, which is extra-urban link. Besides the main line between Rende and the University of Calabria, there are 2 other spurs for the Hospital and for the workshop/deposit in Vaglio Lise.

The three sections (both single and double track) are integrated and represent a single urban mobility system. The total length of the track is about 17 km (16.893 km)

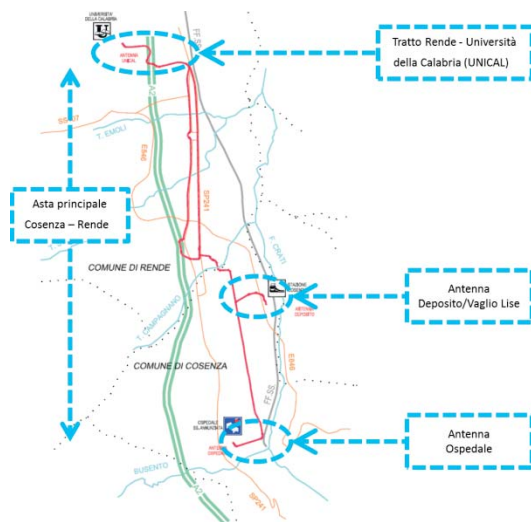

Besides the design of the tramway line, the project has required the reorganization of the whole road section interested by the tramway especially as far as the existing/new intersections and transversal road network are concerned. The design of the tramway line had to take into account specific geometrical conditions given by the tramway vehicle especially for sections without electrification where the system has to count solely on the battery power system.

The works include:

- electric power and traction systems,
- signalling/safety systems,
- telecommunication systems.

The project also includes a workshop and a depot for the tramway vehicles, the design of stops and of the terminal stations, the power electrical supply system, the signalling and safety systems, the electrical stations for the traction system.

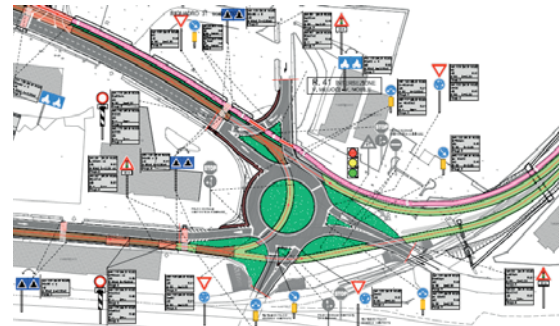

Special care has been paid for the design of the 35 stops from both the architectural and structural point of view. The study was concentrated on the architectural concept and a subsequent step of choosing the materials and the right proportion of the structural elements.

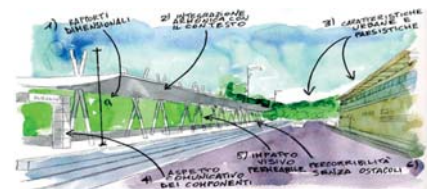

The detailed design has also incorporated bicycle path and an urban park for improving the inclusion of the new system into the urban environment.



TROLLEYBUS TRANSPORT SYSTEM IN VERONA

Location:	Verona, Italy
Client:	CONSORTIUM: INTEGRA – CLEA – NUOVA MAZZI - ALPIQ ENERTRANS - ALPIQ INTEC ITALIA - VOSSLOH KIEPE S.A. AZIENDA MOBILTA' TRASPORTI VERONA
Services:	Final and Detailed Design, Preliminary Environmental Studies, Landscaping Report
Period:	07/2010 – 09/2018
Construction cost:	Euro 79,262,249

Project Description:

The project involves the construction of 4 trolleybus lines to be integrated into the urban public transport system made of buses. The trolley bus system has been conceived for the two main axes of the city which are also the most trafficked ones, respectively North to South and West to East. The new system aims at connecting important city sites such as the City Hospitals, the Historic Centre, the Exhibition Centre, the Railway Station, the University and main parking, for a total length of approx. 24 km of lines, out of which about 17 km are served by electric traction and the rest independently driven.

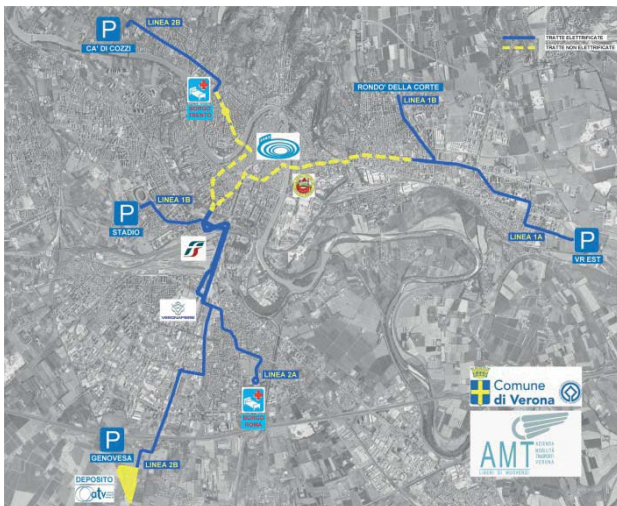

Because of the history of the town, the network of streets interested by the new lines have to undertake deep functional reorganisation, with consequent adaptation.

Particular attention was dedicated to the optimization of the system, in order to maximize efficiency and make it as much



attractive and convenient as possible for citizens and visitors. In this regard, the design of "bus lanes" to separate traffic, allowing vehicles to avoid congestion points, together with synchronization of traffic lights was purposely studied in order to create as unimpeded flow of traffic along the interested itineraries.

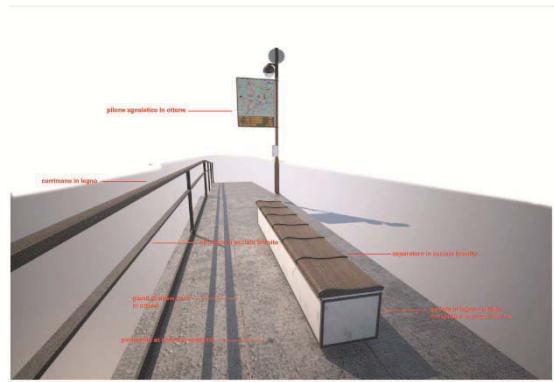

It is worth to add that an innovative trolleybus system has been selected. The vehicles will run on rubber tires and will be equipped with the so-called "virtual track system" allowing the automatic get-in/get-off in a similar way as a railway system (this is the second application in Italy following that of the city of Pescara)





The project also includes the vehicle depot and business center for the operator and will allow a rationalization of the traffic of both private cars and pedestrians.

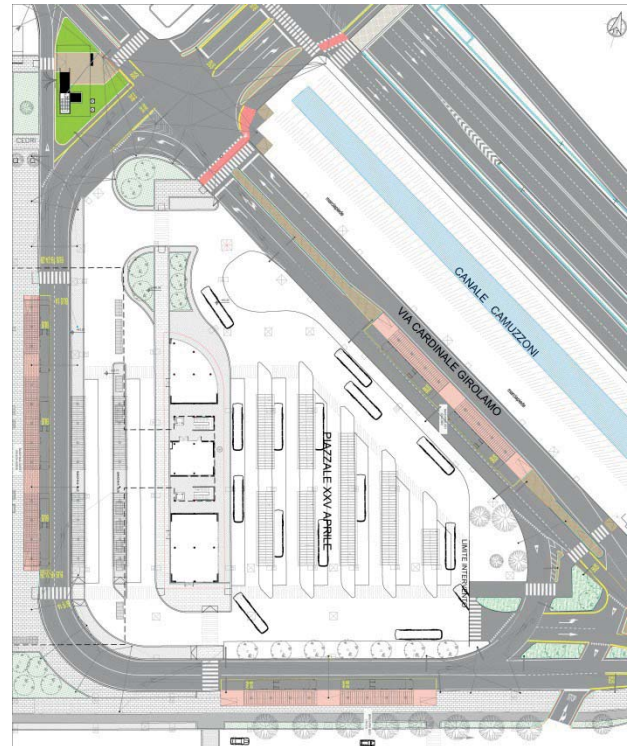

AUTOMATIC METROPOLITAN LIGHT RAILWAY FOR THE CITY OF PALERMO – FIRST LINE: ORETO – NOTARBARTOLO

Location:	Sicily, Italy
Client:	Municipality of Palermo
Services:	Preliminary design, preliminary safety indications and specifications, environmental impact study, geological and geotechnical studies and investigations
Period:	09/2005 – 05/2016
Construction cost:	Euro 478.040.156

Project Description:

The project concerned a first functional section of the metropolitan light railway of Palermo, running in a north-south direction across the central city area, from the intersection of Oreto and the ring road (Viale della Regione Siciliana) to the Notarbartolo railway station, for a total length of 6.5 km, plus a 0.5 km link to the depot. The line section includes 9 stations which are (south-north): *Svincolo Oreto, Oreto Sud, Oreto Nord, Giulio Cesare, Borsa, Massimo, Politeama, Archimede, Notarbartolo*.

The horizontal and vertical layout of the line had to take into consideration the restrictions imposed by the existing buildings, the reality of the site concerned and the compatibility of the future extension of the line towards Mondello by two routes, via Notarbartolo or via Gentili and the Stadium, as well as the normal requirements of an automatic metropolitan railway system.

The line features include a maximum longitudinal gradient of 4%, a horizontal curve radius ranging from a minimum of 200 m, to a maximum of 600 m, and maximum rail depth below ground of 32 m.

The project includes the following line and station (non system) installations:

- mechanical and ventilation systems
- water supply and fire-fighting installations
- special electrical systems
- lighting and motive power systems for line and stations
- earthing system
- cableways for the system installations
- interface between the "non system" installations and the Industrial plc Unit;
- fire detection system
- system for controlling the accesses to the plan area
- automatic ticketing system
- escalators and elevators.

Nine *intermediate ventilation wells* are foreseen, located between stations, which serve to provide normal operation and emergency ventilation, and also for draining water from the line in the sections between stations with minimum levels. There will also be two accesses from the ground level, one for the operator and the other (separate) one to allow access to the line by firemen in the event of an emergency, as required by law.

Most of the line will have a *double barrel tunnel section*, each with a single track and a circular section, achieved by tunnelling using a shielded full-section cutter. Only the first stretch, between the depot and the *Svincolo Oreto* station, and the last section of the switch area for the inversion of the trains, located after the *Notarbartolo* station and just before the end of the first functional line section, will have a double track single-barrel, cut and cover tunnel with a rectangular section, made with r.c. diaphragms.

The circular section single-track tunnel has a maximum diameter of 5.3 m (Ansaldo system) and a minimum diameter of 4.7 m (VAL system), according to the rolling stock adopted.

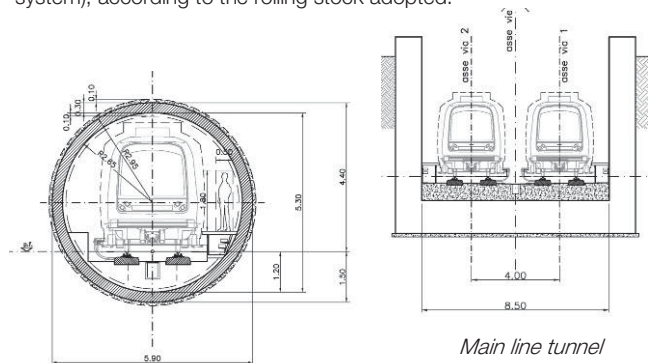

Main line tunnel

The project includes a *workshop and depot area* of 96,464 m² initially for 16 trains, and subsequently capable of handling up to 40 trains. This area will serve as a depot for the trains when not in operations, for their inspection, maintenance and cleaning, and also for their repair and technical revision.

All *stations* are below ground with a central platform, with the exception of *Svincolo Oreto* which has lateral platforms, and *Archimede* which has overlying platforms, and a minimum of two accesses to above ground according to the current standards. The stations of *Oreto Sud, Giulio Cesare, Politeama* and *Notarbartolo* have a standard rectangular plan and a central island, and are built by the top down system, on three levels, entrance hall, mezzanine floor and train level.

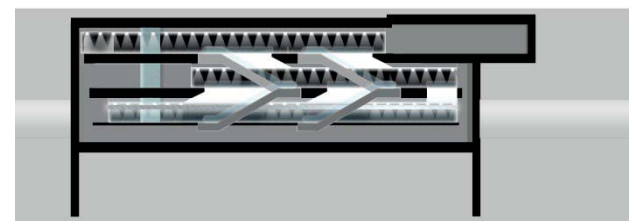
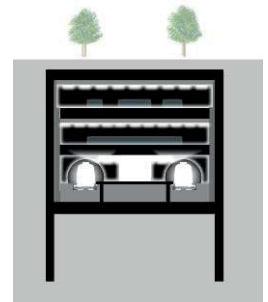

The other stations - *Oreto, Oreto Nord, Borsa, Massimo* and *Archimede* are all special.

For example, the *station of Svincolo Oreto* has a rectangular plan with lateral platforms, but also has a trapezoidal-shaped extension, towards Notarbartolo, to create a space between the lines to allow the lowering of the two mechanized shields for boring the circular tunnels in safe conditions. This station has only two levels: the entrance hall and the train level.

The *station of Oreto Nord*, thanks to the limited width of the street (via Perez) where it is located, is long and narrow, with stairs linking the entrance hall to the train level and the plant areas, and two

tunnels (one for each track) realized with traditional tunnelling methods and connected by corridors to station "box".

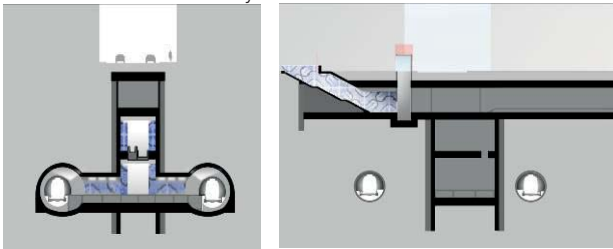

Le *stations of Borsa and Massimo*, have an almost square plan owing to the particular environmental constraints, achieved by top down excavation, which includes the entrance hall, the stairs/escalators to the train level, the technological plants and part of the platform. The rest of the platform length will be served by two polycentric section tunnels realized by traditional methods.

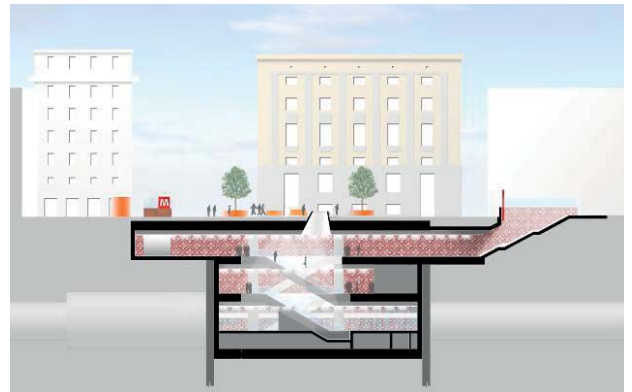
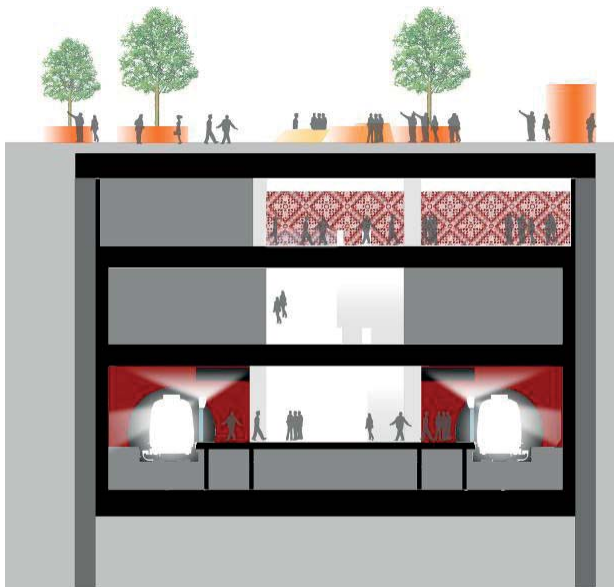
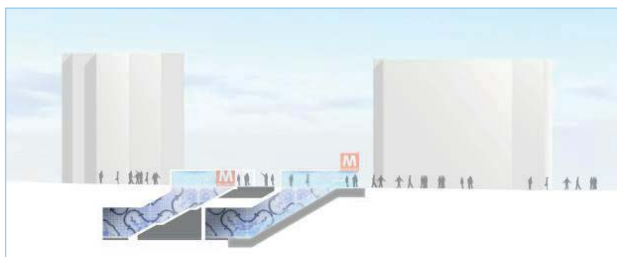

The station of Archimede, which will also be the interchange structure for connection to future lines, has overlying platforms owing to the limited space available for their location.

TECHNITAL carried out the services in the Temporary Association of companies formed by Systra S.A. (lead company) – Technital S.p.A. – INECO S.A. – Lombardi-Reico Ingegneria S.r.l. – Dominique Perrault Architecte. TECHNITAL's share amounted to 39% of the total contract value.

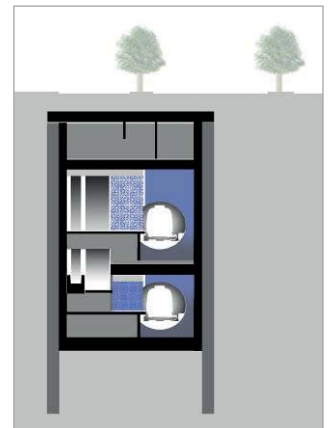

The Preliminary design was officially approved on 17/4/2008.

LIGHT RAIL 2B OF SANTO DOMINGO – CABLE STAYED BRIDGE OVER RIO OZAMA

Location:	DOMINICAN REPUBLIC
Client:	Yellow Ingenieros & Arquitectos
Services:	Engineering Consultancy Services for the independent check of the detailed design of the bridge for a future construction Tender
Period:	05/2014 – 12/2014
Construction cost:	Euro 50,000,000

Project Description:

The Santo Domingo Metro is a light rail system in Santo Domingo, the capital of the Dominican Republic. It is the most extensive metro system in the insular Caribbean and Central American region by length and number of stations.

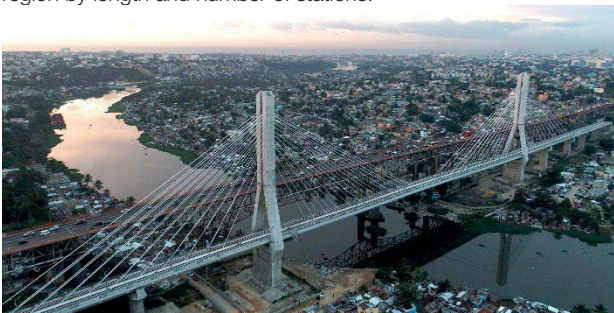

Line 2 runs from western to the eastern part of the city and its extension 2b will include a cable stayed bridge over Rio Ozama, parallel to the existing road Francisco del Rosario Sanchez. The bridge has a deck about 520 m long, subdivided in 5 spans: the central one (between the pylons) is 270 m long, while the 2 adjacent ones on each side are 65 m and 60 m respectively.

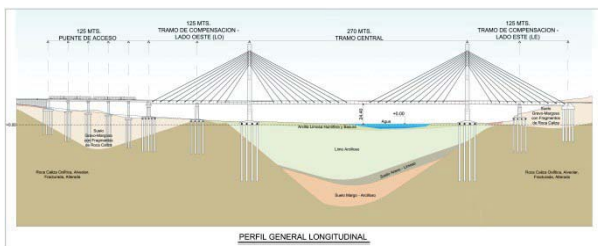

The deck is made of a cellular box of concrete 3.05 m high and 11.9 m wide.

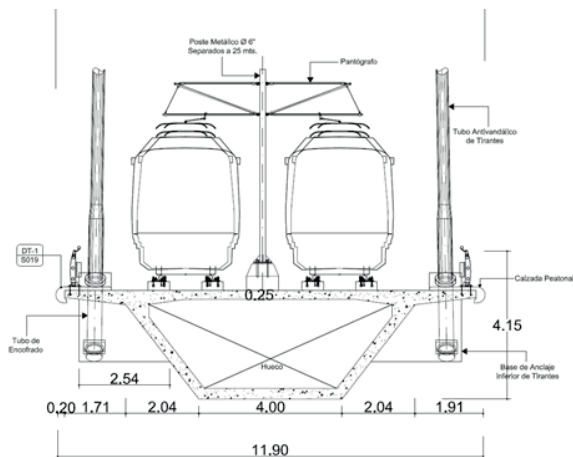

The cable arrangement refers to a semi-fan system with two inclined cable planes

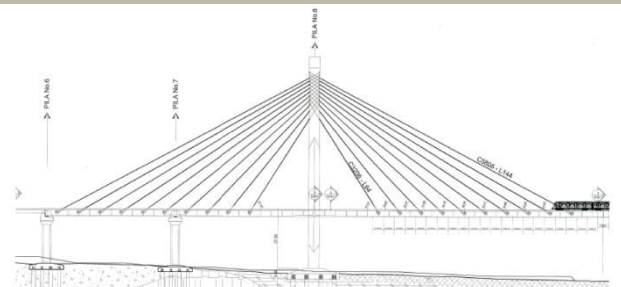

The bridge has to serve a metro line in a region interested by high risks of earthquakes and hurricanes and therefore the following analysis are required:

1. Static and seismic analysis to be developed in the elastic range with a three-dimensional model representative of the existing project.
2. Rail-structure interaction analysis to be carried out by a non-linear model, in accordance with UIC Codes 776-2, 776-4 and 774-3.
3. Preliminary runnability analysis (using axle forces moving along the deck) to evaluate the dynamic performances of this bridge under moving train effects.
4. "Robustness" analysis of the structure when exposed to accidental events, due to train derailment, sabotage or extreme natural events, which cause the failure of one or more stays..
5. Tests in the wind tunnel and related analysis for:

- Study of a sectional model for the identification of polar and static aeroelastic derivatives and the response of the deck to the vortex shedding.
- Analysis of bridge serviceability related to the risk of overturning of the vehicles running under cross wind.
- Study of proper measures able to increase the serviceability of the bridge, for instance by adding wind barriers.



RAILWAY LINK FROM BARI TOWN CENTER TO BARI AIRPORT

Location:	Bari, Italy
Client:	DEC - Degennaro Costruzioni, in association with IPA Precast
Services:	Detailed design
Period:	09/2008 – 06/2009
Construction cost:	Euro 52,212,000

Project Description:

The project will increase the accessibility of the Bari-Palese airport, which is located around 10 km north-westside from the town center and is at present accessible only by road, through a new by-pass along the existing Bari-Barletta railway line, to directly connect Bari central station and the passenger terminal (*Fermata Aerostazione*).

The design speed of the new line is between 50 and 120 km/h. The design train frequency has been assumed at 50 minutes. The double track has the standard European gauge, with rails weighing 50 kg/m, wooden sleepers on ballast. A 400 m long section will have rail mounted on concrete prefabricated slab and anti-noise and anti-vibration carpet.

For environmental reasons and due to the need to cross the existing main railway line Bologna-Bari as well as an old part of the airport area not in operation, and existing military installations, the new line is mainly below ground level, partially in tunnel and partially in cutting, and very little on embankment.

Two crossovers will maintain the continuity of the intersected local roads.

The new rail section, which has a total length 7.7 km, includes also another station (*Fermata Europa*), serving an existing settlement.

In the cases of both *Aerostazione* and *Europa* stations the train level is underground, and the passenger access hall at ground level. Technical rooms are located at intermediate level. Passenger platforms are 95 m long and 3.5 m wide, accessible by mobile escalator (*Aerostazione* only) and lift as well as by staircase. The *Aerostazione* station is also connected to the passenger terminal through an underground tunnel, 200 m long, to avoid any interference with the existing airport access road. A third building, the *Fabbricato Transito*, allows a covered double level passage between the above tunnel to and from the *Aerostazione* rail station and the passenger terminal ground floor.

As regards the architectural design of the station buildings, a large use of continuous glass facades as well as of metal sheet roofings has been applied.

Aerial views of the *Aerostazione* station and the *Fabbricato Transito* follow.

The double track tunnel will be (internally) 9.0 m wide and 6,4 m high, and will be realised through a prefabricated structure, as per the typical cross section below, with the aim to save both



construction time and cost, whereas in the intermediate design a cast in place structure was envisaged. The total length of the prefabricated section is around 1.9 km.

A special box-structure to be "launched" by pushing jacks has been designed to underpass the existing Bologna-Bari railway line



cutting the relevant embankment with no interference to the track and the rail service, as in the following figure

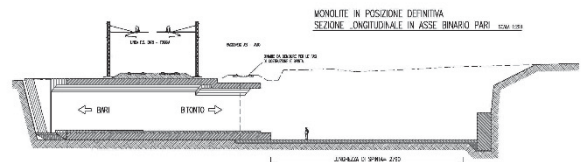
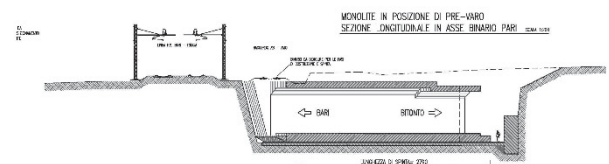
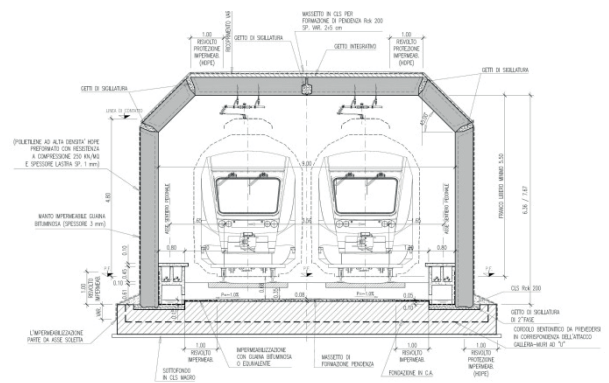

The drainage system was designed, on the basis of a hydrological study, with the aim of avoiding rain water remaining at track level, taking into account the local piezometric level and soil permeability. Works include continuous dispersion trenches on both sides of the open air railway sections as well as treatment tanks for the only water coming from station road side paved areas, and from the first line section 500 m long due to groundwater high level.

Railway equipment includes:

- electric traction works (3,000 V),
- automatic control system
- telecommunication systems,
- signalling system.

A special security equipment was designed, to protect some existing military and civil aviation installations.



TECHNITAL S.p.A.
Via Carlo Cattaneo, 20 - 37121 Verona - Italy
Tel.: +39 045-8053611 - Fax: +39 045-8011558
tender.office@technital.it

We Plan the World of Tomorrow